

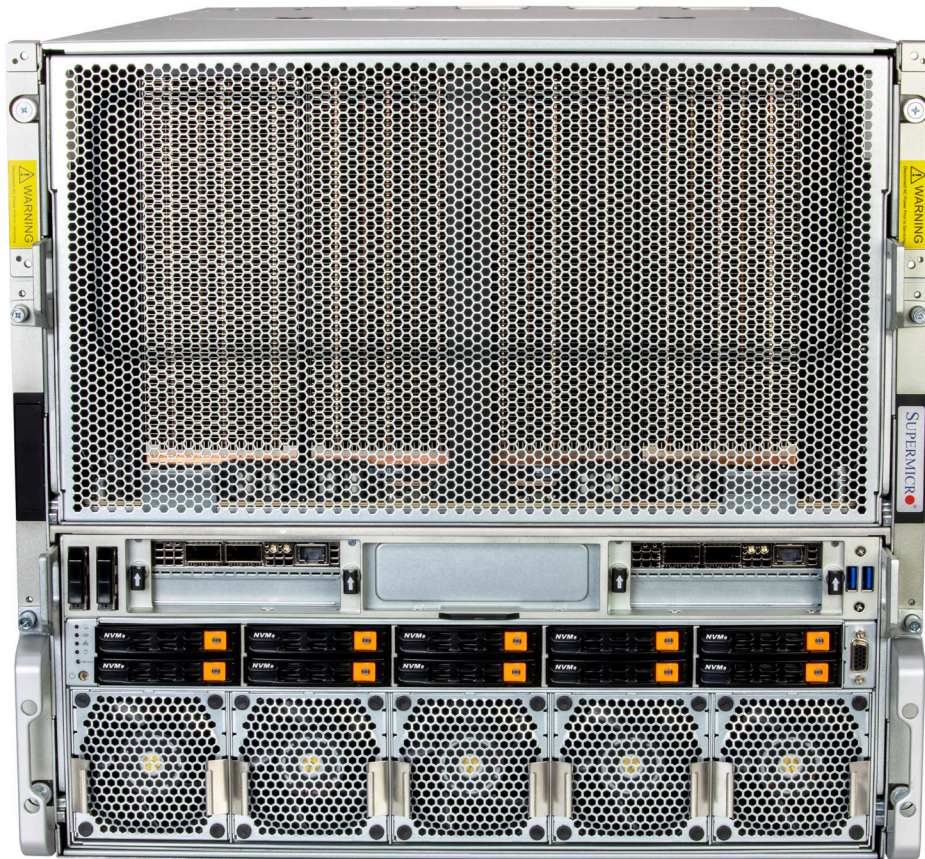

SUPERSERVER[®] SYS-A21GE-NBRT



USER'S MANUAL

Revision 1.0

The information in this User's Manual has been carefully reviewed and is believed to be accurate. The vendor assumes no responsibility for any inaccuracies that may be contained in this document, and makes no commitment to update or to keep current the information in this manual, or to notify any person or organization of the updates. Please Note: For the most up-to-date version of this manual, please see our website at www.supermicro.com.

Super Micro Computer, Inc. ("Supermicro") reserves the right to make changes to the product described in this manual at any time and without notice. This product, including software and documentation, is the property of Supermicro and/or its licensors, and is supplied only under a license. Any use or reproduction of this product is not allowed, except as expressly permitted by the terms of said license.

IN NO EVENT WILL Super Micro Computer, Inc. BE LIABLE FOR DIRECT, INDIRECT, SPECIAL, INCIDENTAL, SPECULATIVE OR CONSEQUENTIAL DAMAGES ARISING FROM THE USE OR INABILITY TO USE THIS PRODUCT OR DOCUMENTATION, EVEN IF ADVISED OF THE POSSIBILITY OF SUCH DAMAGES. IN PARTICULAR, SUPER MICRO COMPUTER, INC. SHALL NOT HAVE LIABILITY FOR ANY HARDWARE, SOFTWARE, OR DATA STORED OR USED WITH THE PRODUCT, INCLUDING THE COSTS OF REPAIRING, REPLACING, INTEGRATING, INSTALLING OR RECOVERING SUCH HARDWARE, SOFTWARE, OR DATA.

Any disputes arising between manufacturer and customer shall be governed by the laws of Santa Clara County in the State of California, USA. The State of California, County of Santa Clara shall be the exclusive venue for the resolution of any such disputes. Supermicro's total liability for all claims will not exceed the price paid for the hardware product.

FCC Statement: This equipment has been tested and found to comply with the limits for a Class A or Class B digital device pursuant to Part 15 of the FCC Rules. These limits are designed to provide reasonable protection against harmful interference when the equipment is operated in industrial environment for Class A device or in residential environment for Class B device. This equipment generates, uses, and can radiate radio frequency energy and, if not installed and used in accordance with the manufacturer's instruction manual, may cause harmful interference with radio communications. Operation of this equipment in a residential area is likely to cause harmful interference, in which case you will be required to correct the interference at your own expense.

California Best Management Practices Regulations for Perchlorate Materials: This Perchlorate warning applies only to products containing CR (Manganese Dioxide) Lithium coin cells. Perchlorate Material-special handling may apply. See www.dtsc.ca.gov/hazardouswaste/perchlorate.



WARNING: This product can expose you to chemicals including lead, known to the State of California to cause cancer and birth defects or other reproductive harm. For more information, go to www.P65Warnings.ca.gov.

The products sold by Supermicro are not intended for and will not be used in life support systems, medical equipment, nuclear facilities or systems, aircraft, aircraft devices, aircraft/emergency communication devices or other critical systems whose failure to perform be reasonably expected to result in significant injury or loss of life or catastrophic property damage. Accordingly, Supermicro disclaims any and all liability, and should buyer use or sell such products for use in such ultra-hazardous applications, it does so entirely at its own risk. Furthermore, buyer agrees to fully indemnify, defend and hold Supermicro harmless for and against any and all claims, demands, actions, litigation, and proceedings of any kind arising out of or related to such ultra-hazardous use or sale.

Manual Revision 1.0

Release Date: January 23, 2026

Unless you request and receive written permission from Super Micro Computer, Inc., you may not copy any part of this document. Information in this document is subject to change without notice. Other products and companies referred to herein are trademarks or registered trademarks of their respective companies or mark holders.

Copyright © 2026 by Super Micro Computer, Inc.
All rights reserved.

Printed in the United States of America

Preface

About this Manual

This manual is written for professional system integrators and PC technicians. It provides information for the installation and use of this server. Installation and maintenance should be performed by certified service technicians only.

Please refer to the SYS-A21GE-NBRT server specifications [page](#) on our website for updates on supported memory, processors and operating systems (www.supermicro.com).

Notes

For your system to work properly, please follow the links below to download all necessary drivers/utilities and the user's manual for your server.

- Supermicro product manuals: <https://www.supermicro.com/support/manuals/>
- Product drivers and utilities: <https://www.supermicro.com/wdl/>
- Product safety info: <https://www.supermicro.com/en/about/policies/safety-information>

If you have any questions, please contact our support team at: support@supermicro.com

This manual may be periodically updated without notice. Please check the Supermicro website for possible updates to the manual revision level.

Secure Data Deletion

A secure data deletion tool designed to fully erase all data from storage devices can be found on our website: https://www.supermicro.com/about/policies/disclaimer.cfm?url=/wdl/utility/Lot9_Secure_Data_Deletion_Utility/

Warnings

Special attention should be given to the following symbols used in this manual.



Warning! Indicates important information given to prevent equipment/property damage or personal injury.



Warning! Indicates high voltage may be encountered when performing a procedure.



Warning! Indicates hazardous moving parts may be encountered while handling a fan or components near a fan.

Contents

Chapter 1 Introduction

1.1 Overview.....	9
1.2 System Features	10
Front View	10
Drive Carrier Indicators.....	11
Control Panel.....	12
Rear View.....	13
1.3 Motherboard Block Diagram.....	14
1.4 Motherboard Layout	15
Quick Reference Table.....	16

Chapter 2 Server Installation

2.1 Unpacking the System	18
2.2 Preparing for Setup.....	18
Choosing a Setup Location.....	18
Rack Precautions	19
Server Precautions.....	19
Rack Mounting Considerations	19
Ambient Operating Temperature.....	20
Airflow	20
Mechanical Loading.....	20
Circuit Overloading	20
Reliable Ground.....	20
2.3 Installing the Rails.....	21
Rack-Mounting Instructions.....	21
Overview of the Rack Rails	21
Adjusting the Rail Length	22
Installing the Rails onto the Rack	22
2.4 Installing the Chassis into a Rack.....	23
Removing the Chassis from the Rack	24

Chapter 3 Maintenance and Component Installation

3.1 Removing Power	26
3.2 Accessing the System.....	26
Removing the GPU Drawer Cover.....	26
Removing the CPU Drawer.....	28

Removing the LPIO Drawer	29
3.3 Static-Sensitive Devices.....	30
Precautions	30
3.4 Processor and Heatsink	31
Processor Overview	31
Installation Overview	32
Installation Procedure Overview	32
Create the Processor Carrier Assembly	33
Assemble the Processor Heatsink Module	37
Remove the Socket Cover	39
Install the PHM.....	40
Removing the PHM.....	43
Removing the Carrier Assembly from the Heatsink	45
Removing the Processor from the Carrier Assembly	46
3.5 Memory Support and Installation	47
Memory Support.....	47
DDR5 Memory Support for 5 th /4 th Gen. Intel Xeon Scalable Processors.....	47
Memory Population for the X13DEG-M Motherboard (with 32 DIMM Slots)	49
Memory Slots.....	51
DIMM Installation	53
DIMM Removal	54
3.7 Motherboard Battery Removal and Installation.....	55
3.6 Storage Drives.....	56
2.5" NVMe SSDs.....	57
Checking the Temperature of an NVMe Drive	58
3.7 System Cooling	59
Changing a System Fan	59
Air Shrouds	60
3.8 Expansion Cards.....	61
Low-Profile PCIe Cards.....	61
LPIO Drawer	61
Risers and I/O Cards	62
Installing Front Riser Cards	63
3.9 Power Supply	64
Replacing the Power Supply.....	64

Chapter 4 Motherboard Connections

4.1 Power Connections	66
4.2 Headers and Connectors	67
4.3 Control Panel.....	68
4.4 Input/Output Ports	72
4.5 Jumpers.....	73
How Jumpers Work.....	73
4.6 LED Indicators.....	75

Chapter 5 Software

5.1 Microsoft Windows OS Installation.....	76
5.2 Driver Installation.....	78
5.3 BMC.....	79
5.4 Logging into the BMC	79

Chapter 6 Optional Components

6.1 PCBs	80
6.2 Cables	80
6.3 Drive Kits	80

Chapter 7 Troubleshooting and Support

7.1 Information Resources	81
Website	81
Direct Link for the SYS-A21GE-NBRT System.....	81
Direct Links for General Support and Information	81
7.2 BMC Interface	82
7.3 Troubleshooting Procedures	83
Before Power On	83
No Power	83
No Video	84
System Boot Failure	84
Memory Errors	84
Losing the System Setup Configuration	84
If the System Becomes Unstable.....	85
Issues with NVMe Storage Devices.....	86
7.4 BIOS POST Codes.....	87
7.5 Technical Support Procedures	87
7.6 Frequently Asked Questions	88

7.7 Battery Removal and Installation	89
Battery Removal.....	89
Proper Battery Disposal	89
Battery Installation.....	89
7.8 Where to Get Replacement Components	90
7.9 Reporting an Issue	90
Returning Merchandise for Service.....	90
7.10 Feedback.....	90
7.11 Contacting Supermicro.....	91

Appendix A Standardized Warning Statements for AC Systems

Appendix B System Specifications

Contacting Supermicro

Headquarters

Address: Super Micro Computer, Inc.
980 Rock Ave.
San Jose, CA 95131 U.S.A.

Tel: +1 (408) 503-8000

Fax: +1 (408) 503-8008

Email: marketing@supermicro.com (General Information)
Sales-USA@supermicro.com (Sales Inquiries)
Government_Sales-USA@supermicro.com (Gov. Sales Inquiries)
support@supermicro.com (Technical Support)
RMA@supermicro.com (RMA Support)
Webmaster@supermicro.com (Webmaster)

Website: www.supermicro.com

Europe

Address: Super Micro Computer B.V.
Het Sterrenbeeld 28, 5215 ML
's-Hertogenbosch, The Netherlands

Tel: +31 (0) 73-6400390

Fax: +31 (0) 73-6416525

Email: Sales_Europe@supermicro.com (Sales Inquiries)
Support_Europe@supermicro.com (Technical Support)
RMA_Europe@supermicro.com (RMA Support)

Website: www.supermicro.nl

Asia-Pacific

Address: Super Micro Computer, Inc.
3F, No. 150, Jian 1st Rd.
Zhonghe Dist., New Taipei City 235
Taiwan (R.O.C)

Tel: +886-(2) 8226-3990

Fax: +886-(2) 8226-3992

Email: Sales-Asia@supermicro.com.tw (Sales Inquiries)
Support@supermicro.com.tw (Technical Support)
RMA@supermicro.com.tw (RMA Support)

Website: www.supermicro.com.tw

Chapter 1

Introduction

1.1 Overview

This chapter provides an outline of the functions and features of the SuperServer SYS-A21GE-NBRT. The system is based on the X13DEG-D motherboard and the CSE-GP1001TS chassis. This is an HPC GPU system that supports Nvidia SXM HGX B200 GPU. The following provides an overview of the specifications and capabilities of the system.

System Overview	
Motherboard	X13DEG-D
Chassis	CSE-GP1001TS
Processors	Supports dual 4th and 5th Gen Intel Xeon Scalable processors in Socket E (LGA 4677), thermal design power (TDP) of up to 350W. - 4th Gen: up to 60 cores and supports SP XCC, SP MCC, and Max Series (HBM) SKUs. - 5th Gen: up to 64 cores and supports SP XCC and SP MCC SKUs.
Memory	Supports up to 8 TB 3DS RDIMM/RDIMM DDR5 (288-pin) ECC memory with speeds up to 5600 MT/s (1PDC) or 4400 MT/s (2DPC) in 32 DIMM slots Note: Memory speed and capacity support depends on the processors used in the system.
GPUs	Eight Nvidia SXM HGX B200 GPUs
Storage	Ten PCIe 5.0 x4 NVMe U.2 drive bays Two onboard NVMe M.2 slots
Expansion Slots	Eight PCIe 5.0 x16 LP slots Two PCIe 5.0 x16 FHHL slots
I/O Ports	One VGA port Two USB 3.0 ports One TPM header
System Cooling	Fifteen heavy-duty, 8-cm hot-swap fans Four internal heavy-duty, 6-cm fans
Power	Six Titanium level 5250 W hot-plug redundant (3+3 redundancy) power supplies
Form Factor	10U; 17.6" x 17.2" x 33.2" (W x H x D), (449 x 339 x 843 cm)

A Quick Reference Guide can be found on the [product page](#) of the Supermicro website.

The following safety models associated with the SYS-A21GE-NBRT have been certified as compliant with UL and CSA: GP1001-H52X13, GP1001-TS.

1.2 System Features

The following views of the system display the main features.

Front View

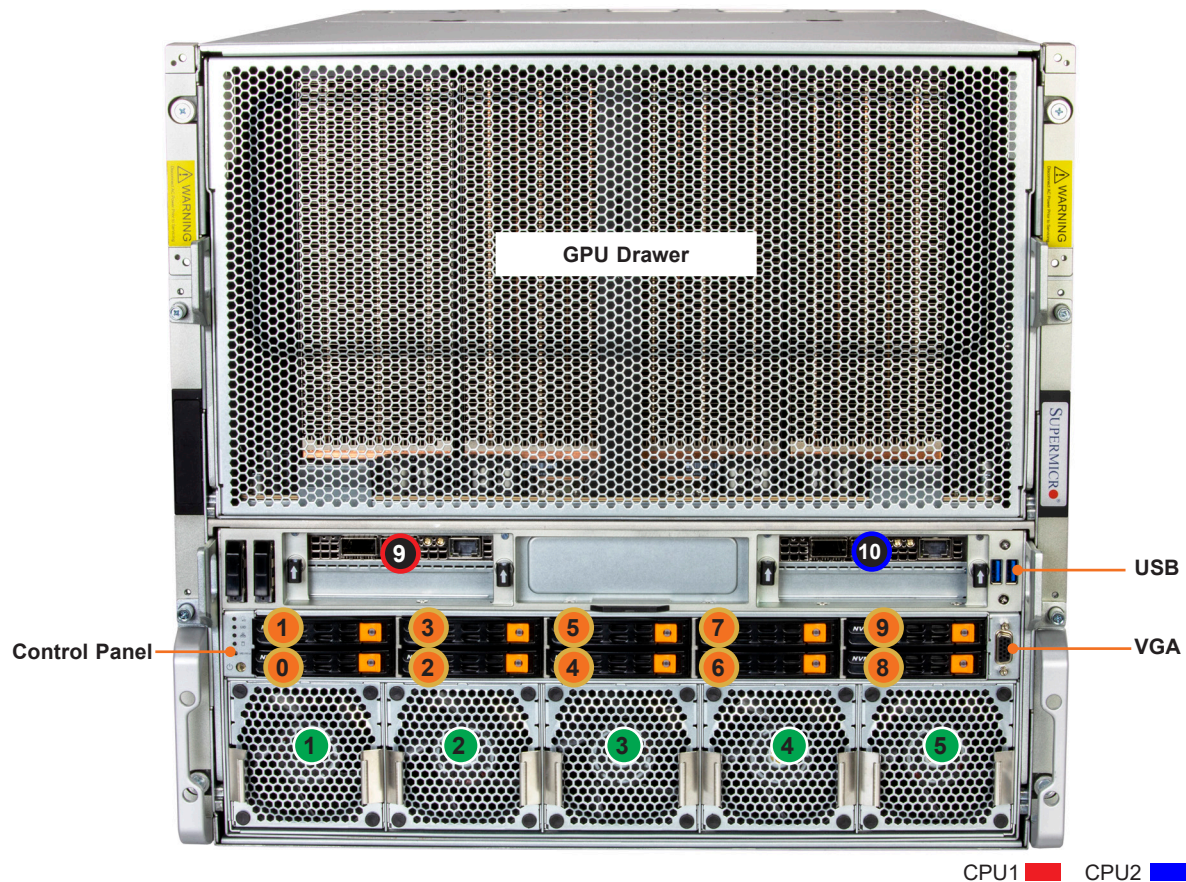

Figure 1-1. System Front View

System Features: Front	
Item	Description
GPU Drawer	GPU tray area
Control Panel	Front control panel with buttons and LEDs (see next section for details)
USB	Two USB 3.0 ports
VGA	VGA (graphics) port
9, 10	PCIe 5.0 x16 FHHL from PLX switch (N-S)
0 to 7	Eight 2.5" hot-swap U.2 NVMe drive bays (connect to PLX for GPU RDMA)
8 to 9	Two 2.5" hot-swap U.2 NVMe drive bays (connect to PLX for OS or local storage)
1 to 5	Five 8-cm fans

Note: Numbers indicate logical locations.

Drive Carrier Indicators

Each drive carrier has two LED indicators: an activity indicator and a status indicator. For RAID configurations using a controller, the meaning of the status indicator is described in the table below. For OS RAID or non-RAID configurations, some LED indications are not supported, such as hot spare.

Drive Carrier LED Indicators			
	Color	Pattern	Device Behavior
Activity LED	Amber	Off	Idle NVMe drive installed
	Amber	Blinking at 4 Hz	Identifying a drive within the rack
	Amber	Solid on	Drive failure
	Amber	Blinking at 1 Hz	Rebuilding drive
	Amber	Blinking for 5 sec. then off	Power on
Status LED	Amber	Blinking at 1 Hz	Do not remove NVMe storage module
	Amber	Off	Idle
	Amber	Blinking at 4 Hz	Identifying drive
	Green	Off	Idle
	Green	Solid on Remains off when amber LED is activated for single bi-colored LED	Idle
	Green	Blinking Remains off when amber LED is activated for single bi-colored LED	I/O activity

Control Panel

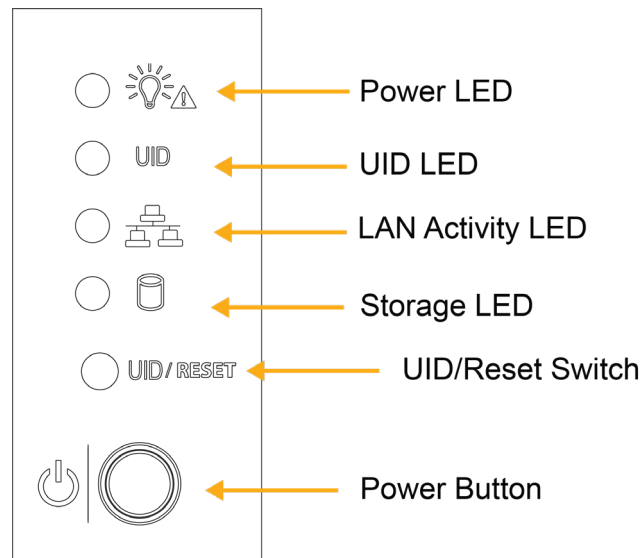

Figure 1-2. Control Panel

Control Panel Features	
Features	Description
Power LED	Indicates when the system power is on, and flashes when a system overheat is detected.
UID LED	Turns on the blue LED on the rear of the chassis; used to locate the server in large racks and server banks
LAN Activity LED	Indicates activity on the LAN port when flashing.
Storage LED	This LED is for SATA drives only and is not used in this server sonfiguration.
UID/Reset Switch LED	The unit identification (UID) button turns on or off the blue light function of the Information LED. This button can also be used to reset the BMC.
Power Button	The main power switch applies or removes primary power from the power supplies to the server but maintains standby power.

Rear View

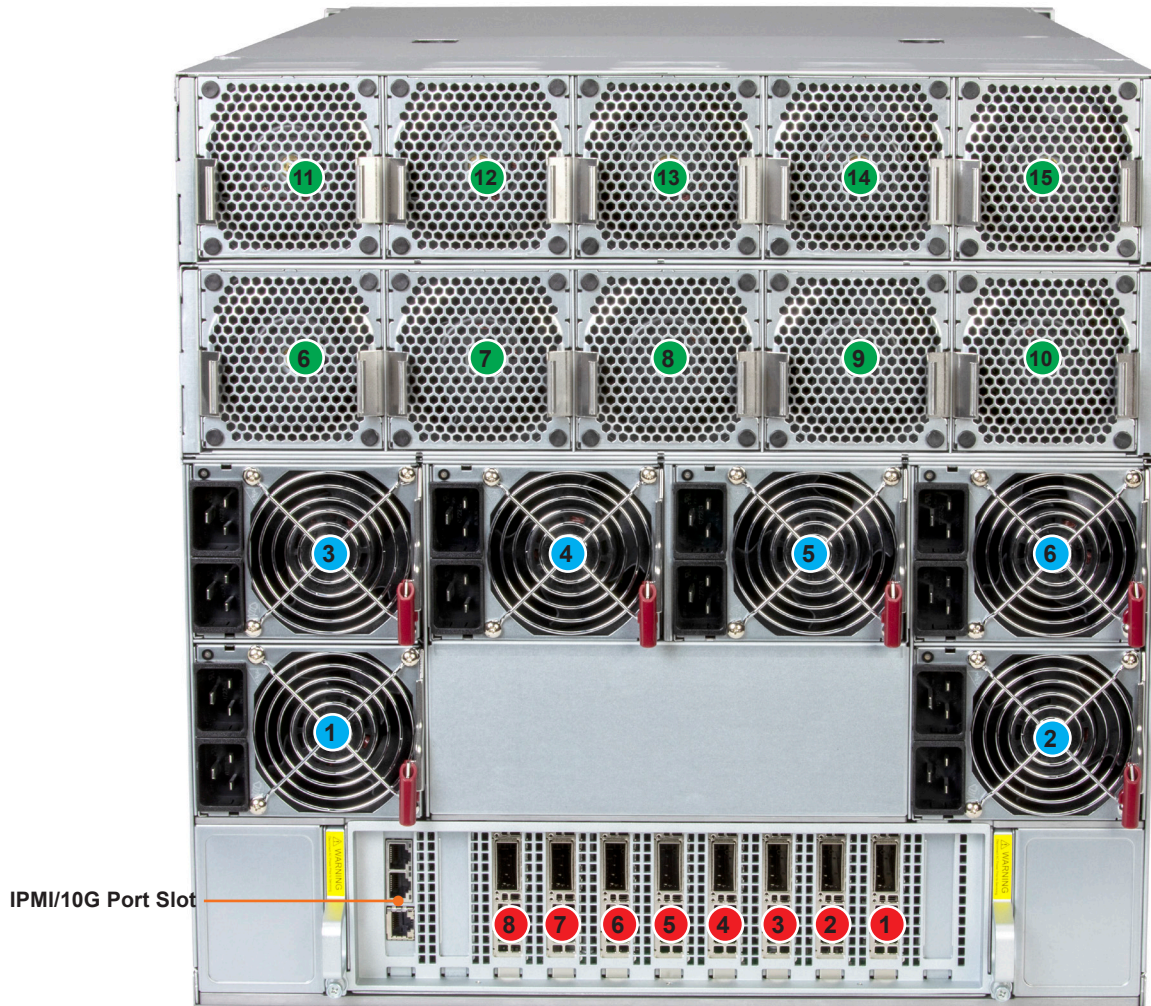

Figure 1-3. System Rear View

System Features: Rear	
Item	Description
IPMI/10G Port Slot	Two RJ45 10GbE ports (Intel® X710) and IPMI port
6 to 15	Ten 8-cm fans (logical locations noted)
1 to 6	Six redundant 5000 W Titanium power supplies (logical locations noted)
1 to 8	Eight PCIe 5.0 x16 LP slots

1.3 Motherboard Block Diagram

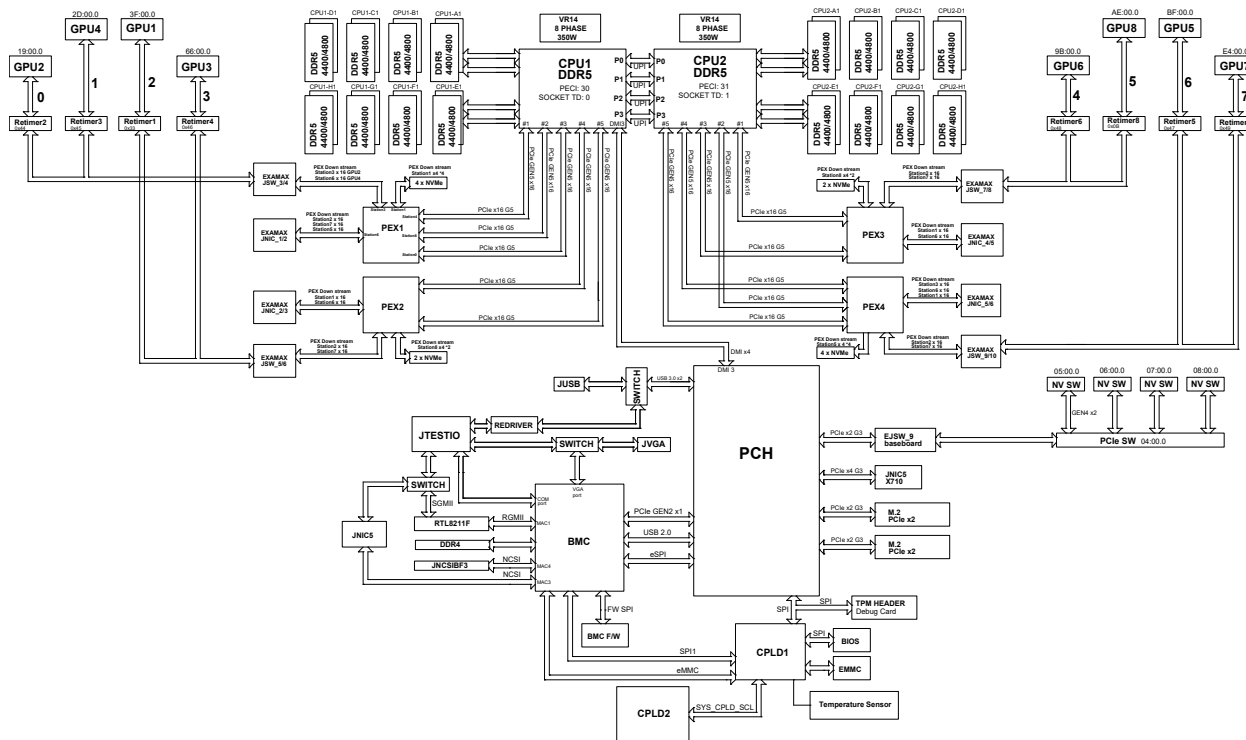

Figure 1-4. Motherboard Block Diagram

1.4 Motherboard Layout

Below is a layout of the X13DEG-D motherboard with jumper, connector and LED locations shown. See the table on the following page for descriptions. For detailed descriptions, pinout information and jumper settings, refer to [Chapter 4](#) or the [Motherboard Manual](#).

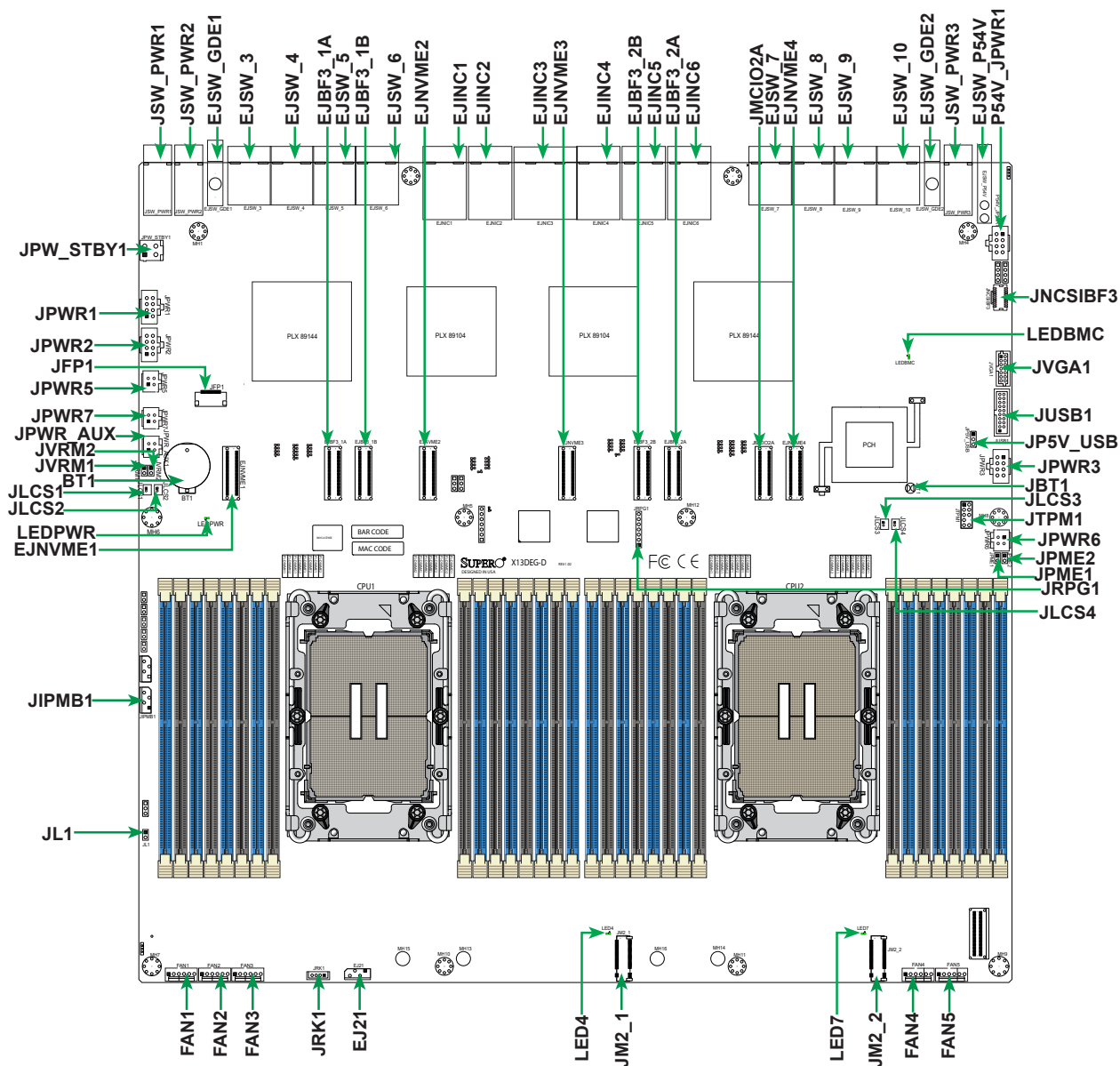

Figure 1-5. Motherboard Layout

Quick Reference Table

Jumper	Description	Default Setting
JBT1	CMOS Clear	Open (Normal)
JVRM1	BMC I ² C/SCL to VRM	Pins 1-2 (Closed)
JVRM2	BMC I ² C/SDA to VRM	Pins 1-2 (Closed)
JPME1, JPME2	Management Engine manufacturing mode	

LED	Description	Status
LED4, LED7	M.2 Activity LED	Blinking Green: M.2 device working normally
LEDBMC	BMC Heartbeat LED	Blinking Green: BMC Normal (Active) Solid Green: BMC Resetting or Cold Rebooting
LEDPWR	Power LED	LED On: Onboard Power On

Connector	Description
Battery (BT1)	Onboard Battery
EJ21	Front Fan Board Sideband
EJNIC1–EJNIC6	AOM-GP805-LPIO PCIe Board Connectors
EJNVME1–EJNVME4	Backplane NVMe Drives Connectors 1–8
EJSW_3–EJSW_10	Midplane Devices Connectors
EJSW_GDE1–EJSW_GDE2	Guide pin to midplane
EJSW_P54V	Fan board Power Connector
FAN1–FAN5	6-pin Cooling Fan Headers
JFP1	Front Control Panel Header
JIPMB1	6-pin BMC External I ² C Header
JL1	Chassis Intrusion Header
JLCS1–JLCS4	Leakage Detection Headers
JM2-1, JM2-2	PCIe 3.0 x2 M.2 Slots (with support of M-Key 2280, and 22110)
JMCIO2A	Backplane NVMe Drives Connectors 9–10
JNCSIBF3	BF-3 Card NC-SI (Network Controller Sideband Interface) Connector
JNVVPP1	VPP I ² C Header
JPWR1–JPWR3, JPWR5–JPWR6 JPWR_AUX1	Midplane Power Connectors
JPW_STBY1	Standby Power Connector
JRK1	VROC Raid Key Header
JRPG1	Connector reserved for manufacturer use for onboard Complex Programmable Logic Device (CPLD) firmware programming

JSW_PWR1–JSW_PWR3 Backplane and Front AOC Power Connectors

JTPM1 Trusted Platform Module/Port 80 Connector

JUSB1 USB 3.0 Header (supports up to two USB connections)

JVGA1 Front Control Panel Header VGA support

P54V_JPWR Main Power Connector

Chapter 2

Server Installation

This chapter provides advice and instructions for mounting your system in a server rack. If your system is not already fully integrated with processors, system memory, etc., refer to [Chapter 3](#) for details on installing those specific components.

Important: Electrostatic Discharge (ESD) can damage electronic components. To prevent such damage to PCBs (printed circuit boards), it is important to use a grounded wrist strap, handle all PCBs by their edges, and keep them in anti-static bags when not in use.

2.1 Unpacking the System

Inspect the box in which the system was shipped, and note if it was damaged. If any equipment appears damaged, file a damage claim with the carrier who delivered it.

Decide on a suitable location for the rack unit that will hold the server. It should be situated in a clean, dust-free area that is well ventilated. Avoid areas where heat, electrical noise, and electromagnetic fields are generated. It will also require a grounded AC power outlet nearby. Be sure to read the precautions and considerations noted or in [Appendix A](#).

2.2 Preparing for Setup

The box in which the system was shipped should include the rackmount hardware needed to install it into the rack. Please read this section in its entirety before you begin the installation.

Choosing a Setup Location

- The chassis should be situated in a clean, dust-free area that is well ventilated. Avoid areas where heat, electrical noise and electromagnetic fields are generated.
- Leave enough clearance in front of the rack, approximately 25 inches, to allow the front door to open completely, and approximately 30 inches of clearance in back of the rack to allow sufficient space for airflow and access when servicing.
- This product should be installed only in a Restricted Access Location, such as a dedicated equipment room or service closet.
- This product is not suitable for use with visual display workplace devices according to §2 of the German Ordinance for Work with Visual Display Units.

Rack Precautions

- Ensure that the leveling jacks on the bottom of the rack are extended to the floor so that the full weight of the rack rests on them.
- In single rack installations, stabilizers should be attached to the rack. In multiple rack installations, the racks should be coupled together.
- Always make sure the rack is stable before extending a server or other component from the rack.
- You should extend only one server or component at a time - extending two or more simultaneously may cause the rack to become unstable.

Server Precautions

- Review the electrical and general safety precautions in [Appendix A](#).
- Determine the placement of each component in the rack before you install the rails.
- Install the heaviest server components at the bottom of the rack first and then work your way up.
- Use a regulating uninterruptible power supply (UPS) to protect the server from power surges and voltage spikes and to keep your system operating in case of a power failure.
- Allow any drives and power supply modules to cool before touching them.
- When not servicing, always keep the front door of the rack and all covers/panels on the servers closed to maintain proper cooling.

Rack Mounting Considerations



Warning! Stability hazard. The rack may tip over causing serious personal injury. Before extending the rack to the installation position, read the installation instructions. Do not put any load on the slide-rail mounted equipment in the installation position. Do not leave the slide-rail mounted equipment in the installation position.



Avertissement! Danger d'instabilité. Le rack peut basculer et provoquer des blessures corporelles graves. Avant d'étendre le rack en position d'installation, lire les instructions d'installation. Ne pas charger l'équipement monté sur rail de glissière en position d'installation. Ne pas laisser l'équipement monté sur rail de glissière en position d'installation.

Important: To prevent bodily injury when mounting or servicing this unit in a rack, you must take special precautions to ensure that the system remains stable. The following guidelines are provided to ensure your safety:

- This unit should be mounted at the bottom of the rack if it is the only unit in the rack.
- When mounting this unit in a partially filled rack, load the rack from the bottom to the top with the heaviest component at the bottom of the rack.
- If the rack is provided with stabilizing devices, install the stabilizers before mounting or servicing the unit in the rack.
- Slide rail mounted equipment is not to be used as a shelf or a work space.

Ambient Operating Temperature

If installed in a closed or multi-unit rack assembly, the ambient operating temperature of the rack environment may be greater than the room's ambient temperature. Therefore, consideration should be given to installing the equipment in an environment compatible with the manufacturer's maximum rated ambient temperature (TMRA).

Airflow

Equipment should be mounted into a rack so that the amount of airflow required for safe operation is not compromised.

Mechanical Loading

Equipment should be mounted into a rack so that a hazardous condition does not arise due to uneven mechanical loading.

Circuit Overloading

Consideration should be given to the connection of the equipment to the power supply circuitry and the effect that any possible overloading of circuits might have on overcurrent protection and power supply wiring. Appropriate consideration of equipment nameplate ratings should be used when addressing this concern.

Reliable Ground

A reliable ground must be maintained at all times. To ensure this, the rack itself should be grounded. Particular attention should be given to power supply connections other than the direct connections to the branch circuit (i.e. the use of power strips, etc.).

2.3 Installing the Rails

The package includes two rail assemblies. Each is specifically designed for the left or right side of the chassis, and so marked. Each rail consists of two sections: a front section which secures to the front post of the rack and a rear section which adjusts in length and secures to the rear post of the rack.

Rack-Mounting Instructions

This section provides information on installing the chassis into a rack unit with the rails provided. There are a variety of rack units on the market, which may mean that the assembly procedure will differ slightly from the instructions provided. You should also refer to the installation instructions that came with the rack unit you are using.

Note: This rail will fit a rack between 28" and 33.5" deep.

Overview of the Rack Rails

The package includes two rail assemblies. Each is specifically designed for the left or right side of the chassis, and so marked. Each rail consists of two sections: a front section which secures to the front post of the rack and a rear section which adjusts in length and secures to the rear post of the rack.

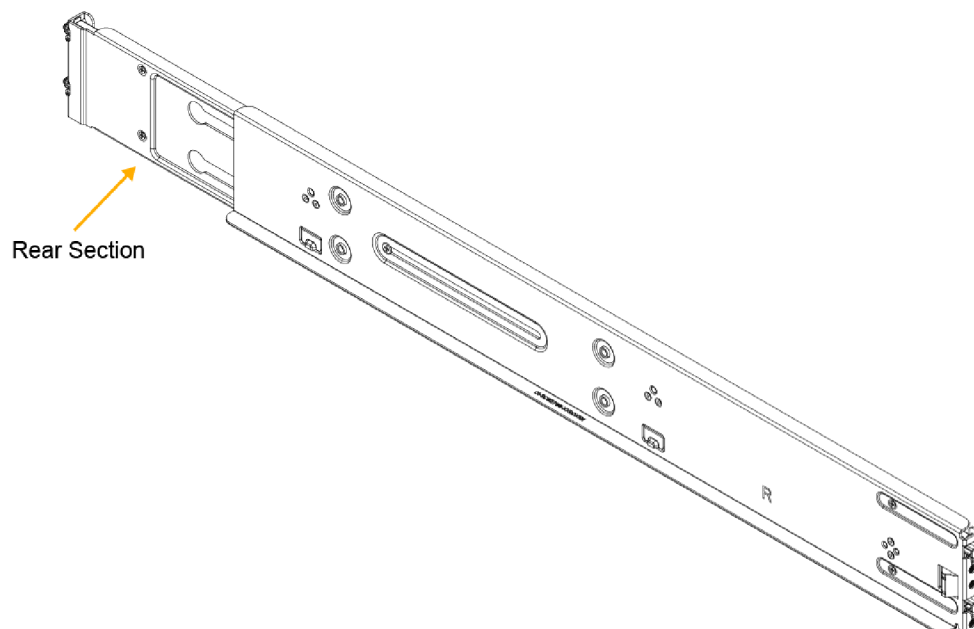

Figure 2-1. Rackmount Rail (Right Rail Assembly Shown)

Adjusting the Rail Length

Each rail assembly has a locking screw to adjust the length of the rail to fit the depth of your rack.

Installing the Rails onto the Rack

1. Loosen the adjusting screw to allow the rear section to slide in the front section.
2. Push the small hooks on the front section of the rail into the holes on the front post of the rack and then down, until the spring-loaded pegs snap into the rack holes. Secure the rail to the rack with screws.
3. Pull out the rear section of the outer rail, adjusting the length until it fits within the posts of the rack and align the small hooks with the appropriate holes on the rear post of the rack. Be sure the rail is level, then mount the rear section onto the rack. Secure the rail with screws.
4. Tighten the adjusting screw.

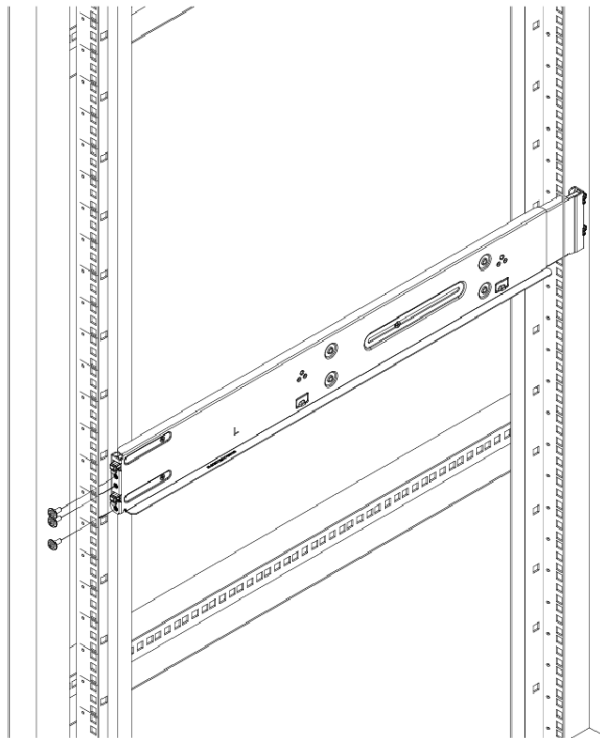

Figure 2-2. Attaching the Rail Front to the Rack (Left Rail Assembly Shown)

Note: Images displayed are for illustrative purposes only. The components installed in your system may or may not look exactly the same as the graphics shown in the manual.

2.4 Installing the Chassis into a Rack

Once rails are attached to the chassis and the rack, the chassis is ready to be installed into a rack.

Important: Use caution when mounting or removing the system from the rack. For large systems, at least one other person must assist during installation or removal. Follow the safety recommendations printed on the rails. Depending on the size of the system, you might need to use a lift.

1. Align the chassis carefully and push it into the extension outer rail, as illustrated below.

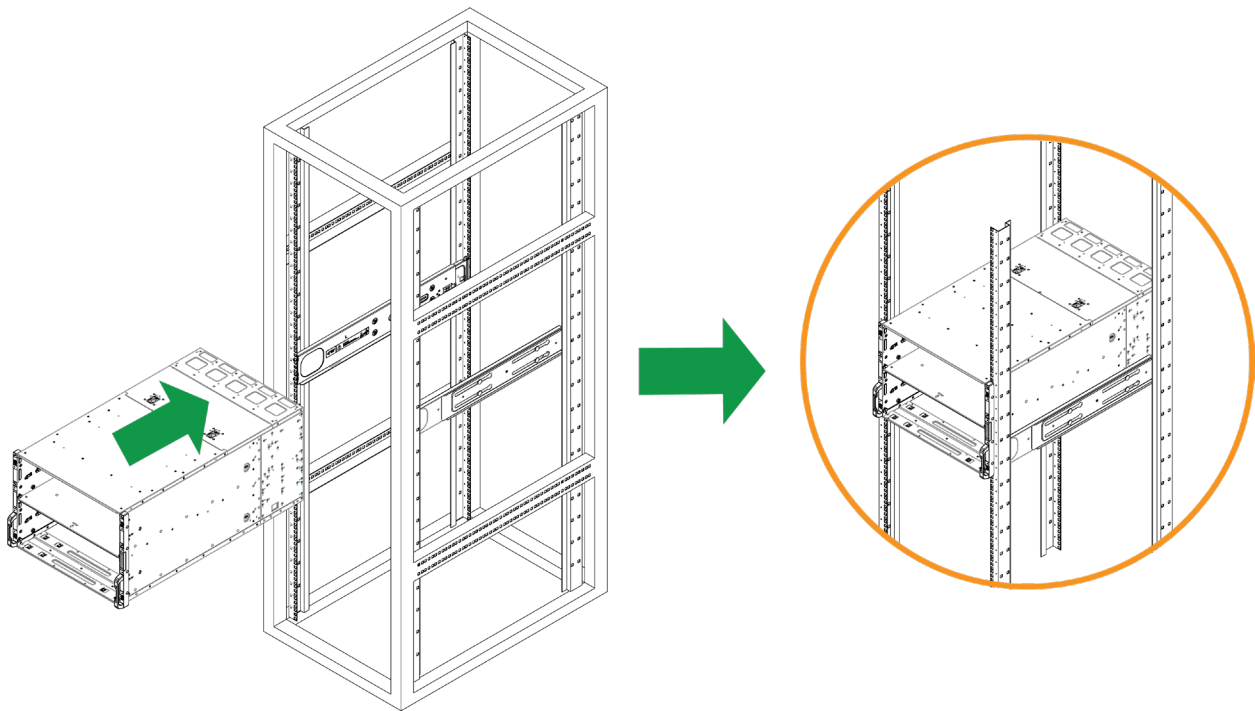

Figure 2-3. Installing the Chassis into the Rack

2. Once the chassis is mounted in the outer rail, it can be pushed all the way into the rack.
3. After you've secured the main chassis to the rack, mount each tray one at a time. Push each tray to the back of the chassis and secure the trays with two flathead screws to prevent them from sliding out.

Note: Images displayed are for illustrative purposes only. The components installed in your system may or may not look exactly the same as the graphics shown in the manual.

Removing the Chassis from the Rack

The process of removing the chassis from the rack is basically the reverse of the installation procedure.

Important: Use caution when mounting or removing the system from the rack. For large systems, at least one other person must assist during installation or removal. Follow the safety recommendations printed on the rails. Depending on the size of the system, you might need to use a lift.

1. Begin by removing the power to your system. See the "Removing Power" on page 1 for more information.
2. Remove all cables connected to the system and all screws from the GPU and CPU tray handles.
3. Pull the GPU and CPU trays out one at a time until all the remaining trays are removed.

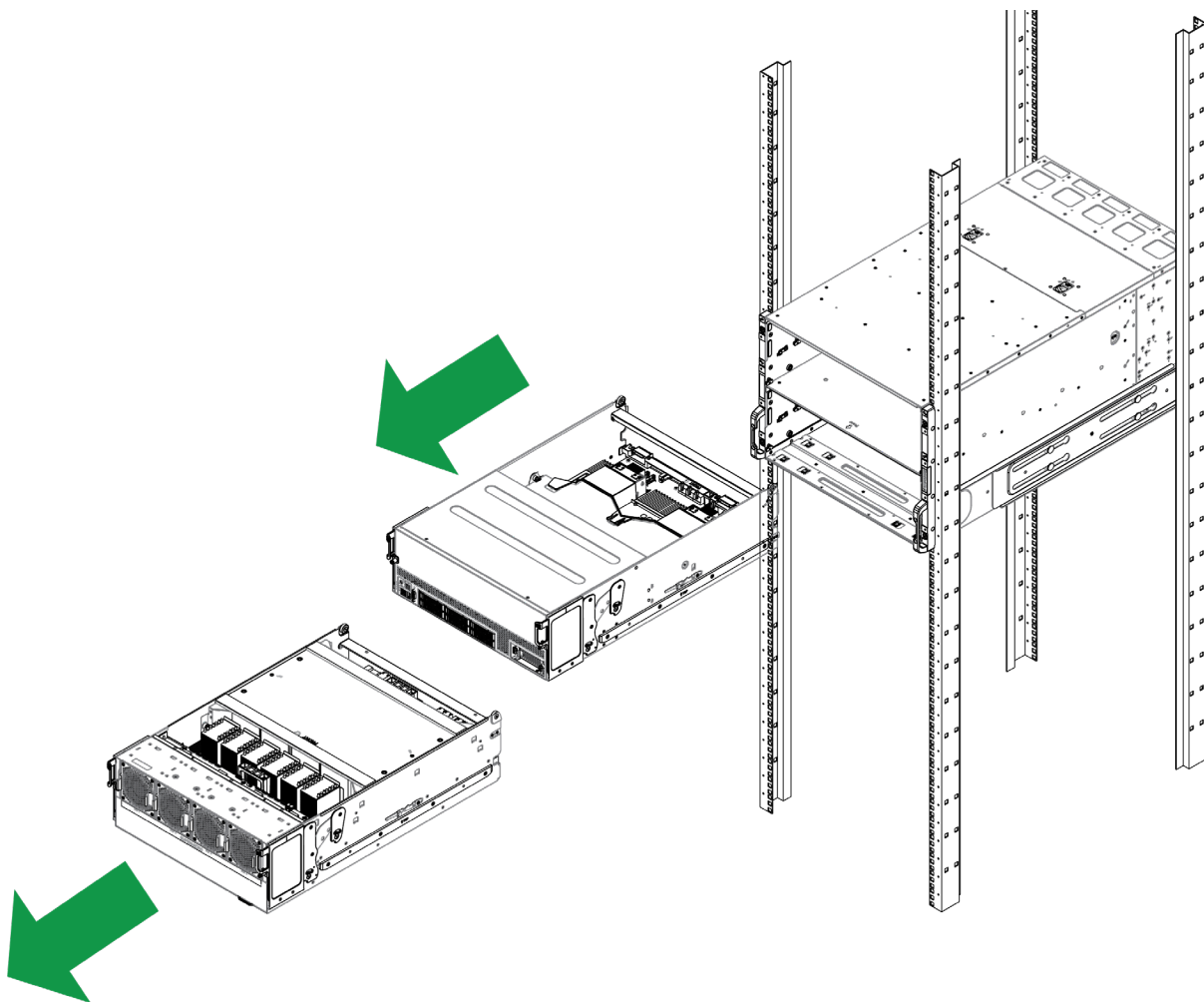

Figure 2-4. Removing the GPU and CPU Trays

4. Remove the power modules on the rear side of the system to reduce the weight of the chassis.
5. Remove the chassis as illustrated below. Using a server lift is the preferred method for removing this server due to its heavy weight.

Important: This figure is for illustrative purposes only. Always install servers to the bottom of a rack first.

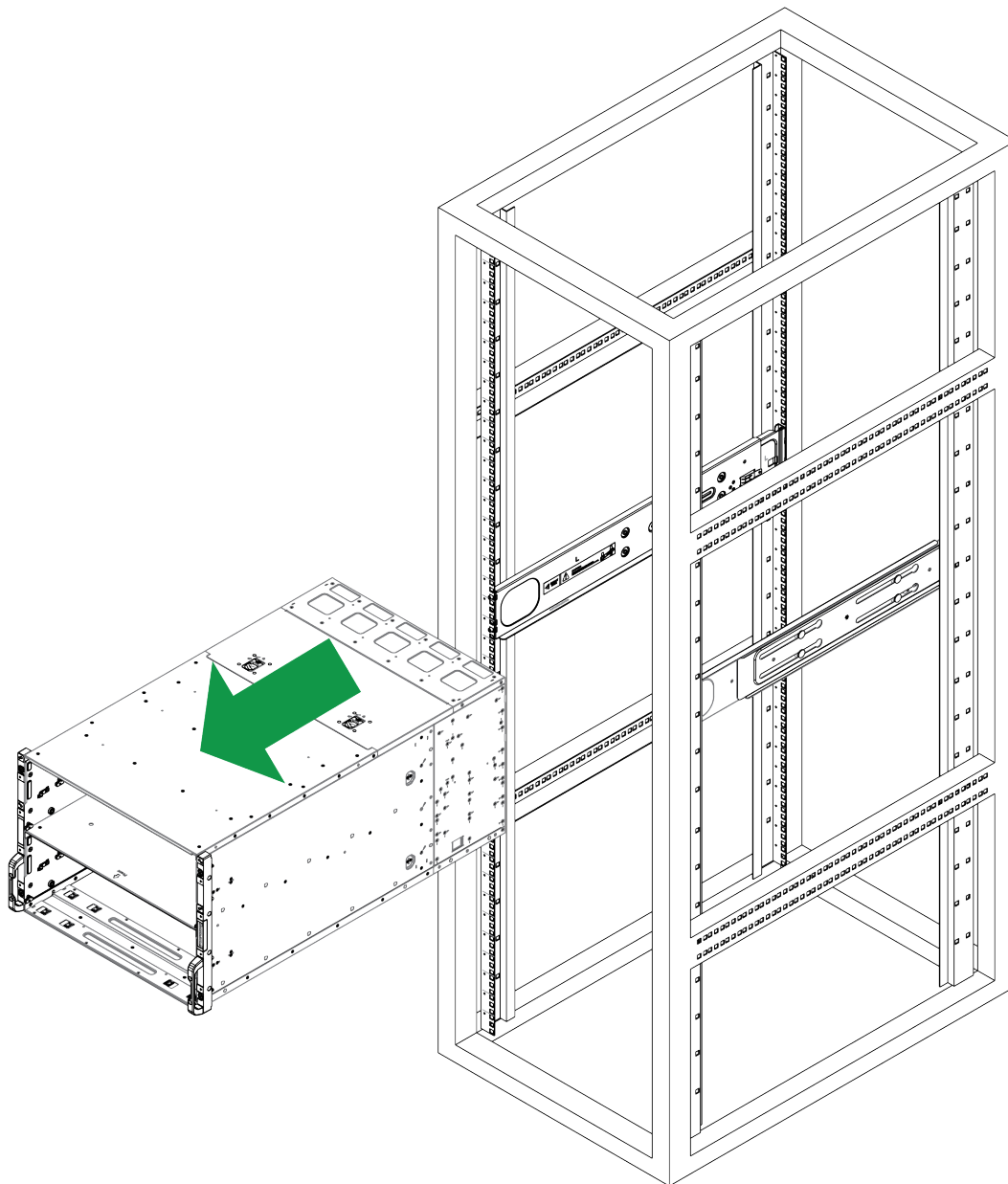

Figure 2-5. Unmounting the Chassis from the Rack

Chapter 3

Maintenance and Component Installation

This chapter provides instructions on installing and replacing main system components. To prevent compatibility issues, only use components that match the specifications and/or part numbers given.

3.1 Removing Power

Use the following procedure to ensure that power has been removed from the system. This step is necessary before servicing GPU trays, CPU trays, or network I/O trays.

1. Use the operating system to power down the system.
2. After the system has completely shut-down, disconnect the AC power cord(s) from the power strip or outlet. (If your system has more than one power supply, remove the AC power cords from all power supply modules.)
3. Disconnect the power cord(s) from the power supply module(s)..

3.2 Accessing the System

Important: Except for short periods of time, do not operate the server without the cover in place. The chassis cover must be in place to allow for proper airflow and to prevent overheating.

Removing the GPU Drawer Cover

You can access the GPU drawer by removing its cover. This GPU drawer has handles to help with carrying the unit safely. To use the GPU drawer, pull out handles.

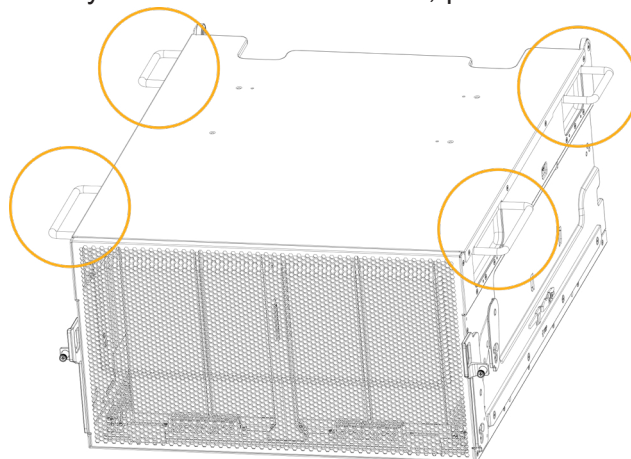

Figure 3-1. GPU Drawer Handles

1. First, remove the drawer from the chassis and remove the screws securing the cover to the GPU drawer.
2. Slide the cover toward the rear of the chassis.
3. Lift the top cover off of the chassis.

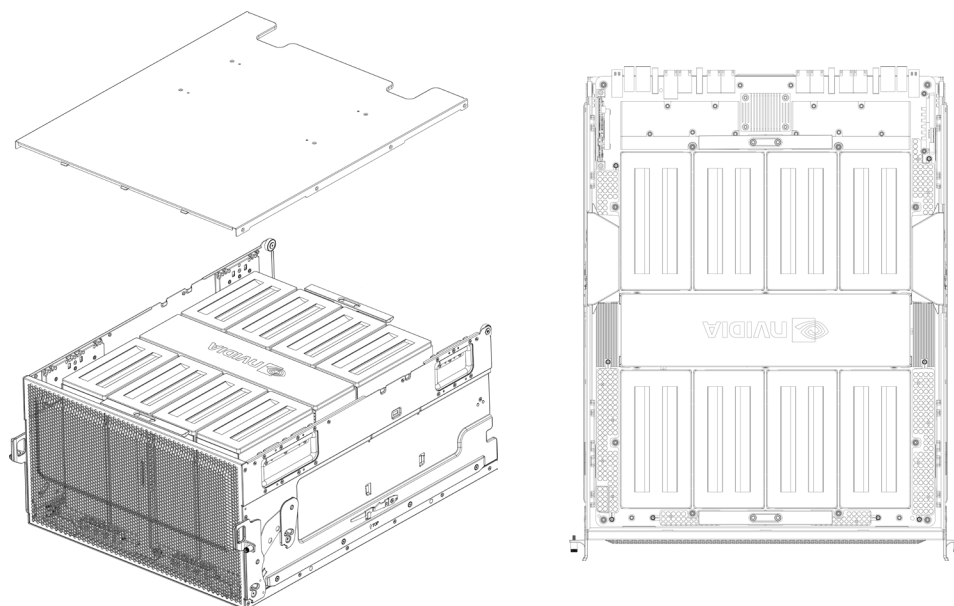

Figure 3-2. Removing the GPU Drawer Cover

Removing the CPU Drawer

The CPU drawer houses the system's motherboard, CPU, and related components. The CPU drawer may be removed from the chassis for maintenance.

1. There are two levers, one located directly on the left and right side of the CPU drawer. Pull these two levers down.

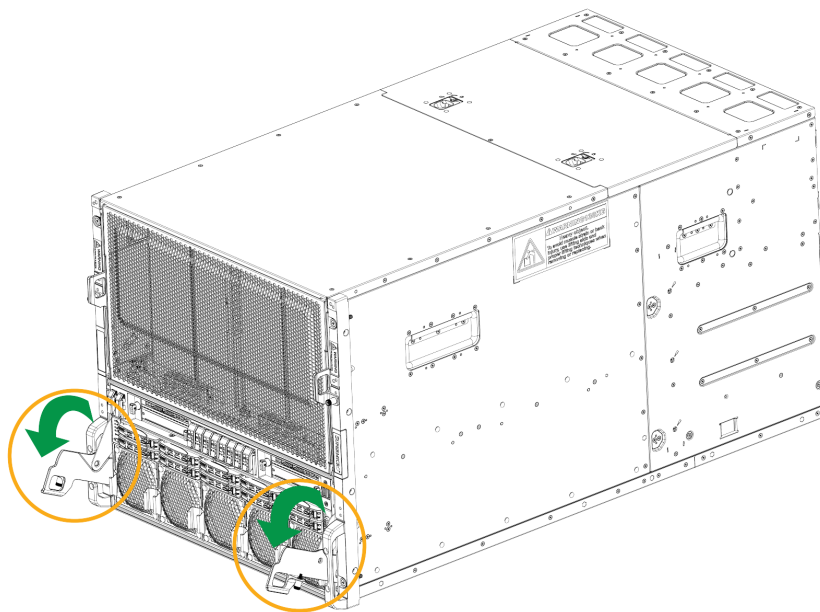

Figure 3-3. CPU Drawer Levers

2. Use these levers to pull the drawer out from the chassis.

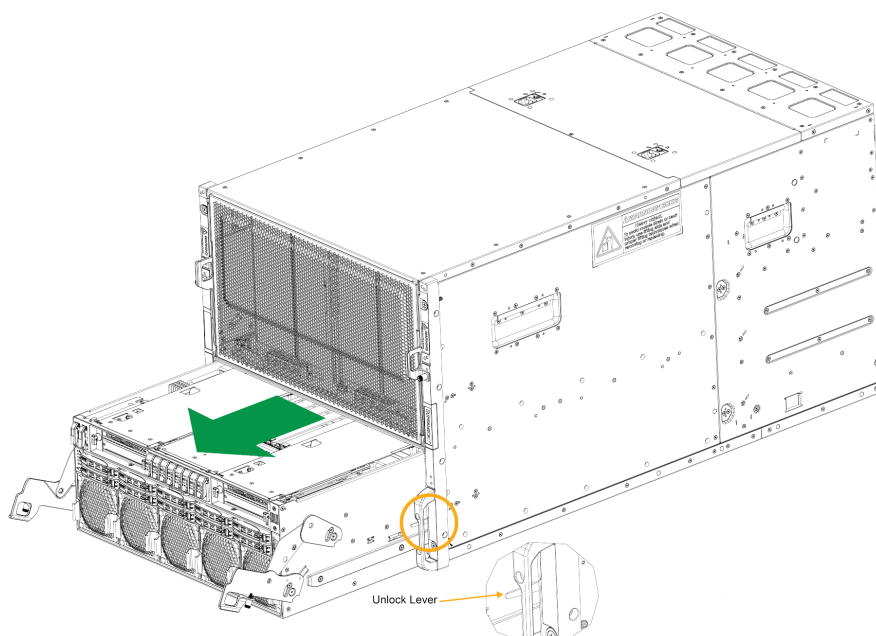

Figure 3-4. Removing the CPU Drawer

Removing the LPIO Drawer

The LPIO drawer supports low-profile PCIe slots. The LPIO drawer may be removed from the chassis for maintenance.

1. Begin by removing the system power. See "Removing Power" on page 1 for more information.
2. Locate the locking levers; there is one lever on the left and right side of the LPIO drawer. Pull these levers outward at the same time to unlock the drawer from the chassis.
3. Use these levers to pull the drawer out from the chassis.

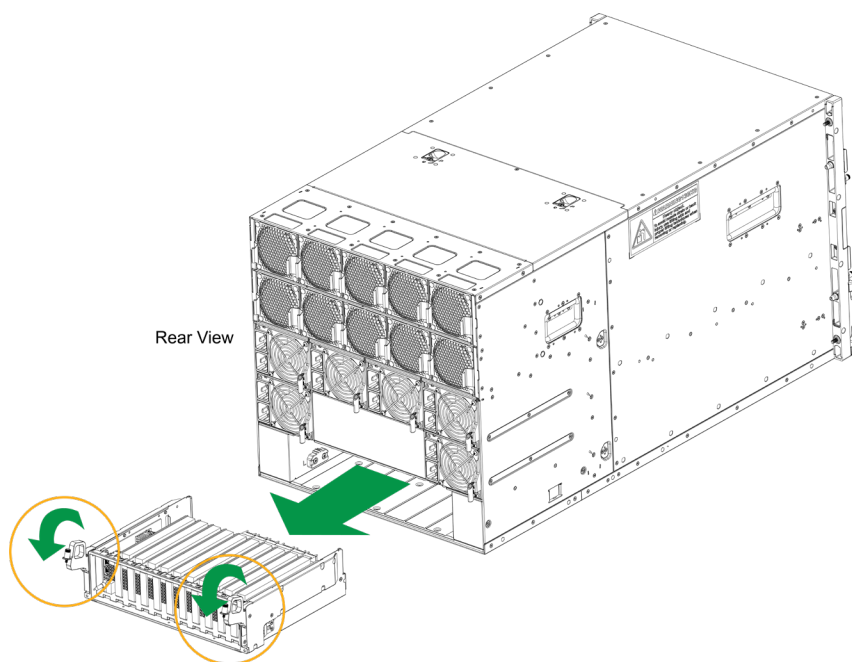

Figure 3-5. Removing the LPIO Drawer

3.3 Static-Sensitive Devices

Electrostatic Discharge (ESD) can damage electronic components. To avoid damaging your motherboard, it is important to handle it very carefully. The following measures are generally sufficient to protect your equipment from ESD.

Precautions

- Use a grounded wrist strap designed to prevent static discharge.
- Touch a grounded metal object before removing the board from the antistatic bag.
- Handle the motherboard by its edges only. Do not touch its components, peripheral chips, memory modules, or gold contacts.
- When handling chips or modules, avoid touching their pins.
- Put the motherboard and peripherals back into their antistatic bags when not in use.
- For grounding purposes, make sure that your computer chassis provides excellent conductivity between the power supply, the case, the mounting fasteners, and the motherboard.
- Use only the correct type of onboard CMOS battery. Do not install the onboard battery upside down to avoid possible explosion.

3.4 Processor and Heatsink

Processor Overview

The motherboard supports 4th and 5th Gen Intel Xeon Scalable processors. The models of each differ in the number of cores, and each requires a different CPU carrier. The CPU carriers differ by the presence or absence of shims and levers. Note that the 5th Gen processors do not support the Max Series for high bandwidth memory (HBM) version.

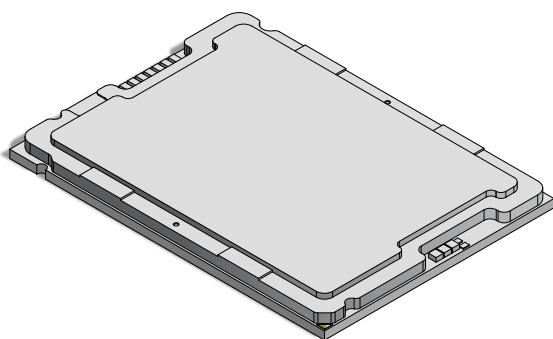

XCC

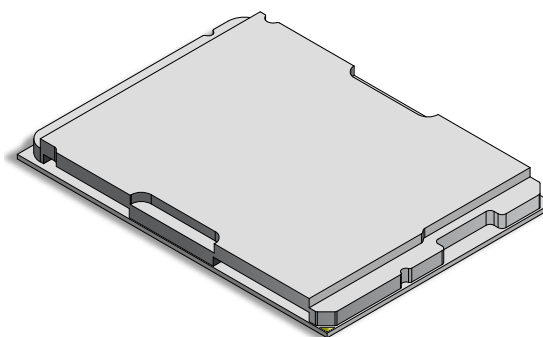

MCC

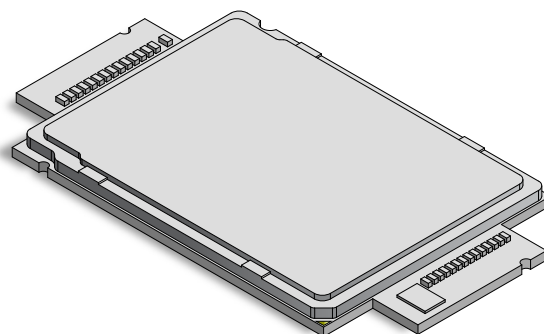

Max

CPU and Carrier Type					
CPU Type	Cores 4th/5th	Carrier Type	Lever	Shim	Carrier Part Number
XCC	60/64	E1A	Yes	No	SKT-1333L-0000-FXC (alt: SKT-1333L-0001-LTS)
MCC	32/36	E1B	Yes	Yes	SKT-1424L-001B-FXC (alt: SKT-1424L-001B-LTS)
Max	56/NA	E1C	No	No	SKT-1425H-001C-FXC (alt: SKT-1425H-001C-LTS)

Installation Overview

The processor (CPU) and processor carrier should be assembled together first to form the processor carrier assembly. This will be attached to the heatsink to form the processor heatsink module (PHM) before being installed onto the CPU socket.

Notes:

- Use ESD protection.
- The system power cords must be removed from all power supplies.
- Check that the plastic protective cover is on the CPU socket and none of the socket pins are bent. If they are, contact your retailer.
- When handling the processor, avoid touching or placing direct pressure on the LGA lands (gold contacts). Improper installation or socket misalignment can cause serious damage to the processor or socket, which may require manufacturer repairs.
- When installing the processor and heatsink, ensure a torque driver set to the correct force is used for each screw.
- Refer to the Supermicro website for updates on processor support.

Installation Procedure Overview

After preparing the system, and following ESD precautions, there are four steps to installing the processor and heatsink onto the motherboard.

1. Attach the processor to a plastic carrier to create the processor carrier assembly.
2. Attach the processor carrier assembly to the heatsink to create the processor heatsink module (PHM).
3. Remove the socket cover.
4. Install the PHM.

Create the Processor Carrier Assembly

Assembling the Process Carrier Assembly

1. Hold the processor with the gold pins (LGA lands) facing down. Locate the gold triangle at the corner of the processor and the corresponding hollowed triangle on the processor carrier as shown below. These triangles indicate the location of pin 1.

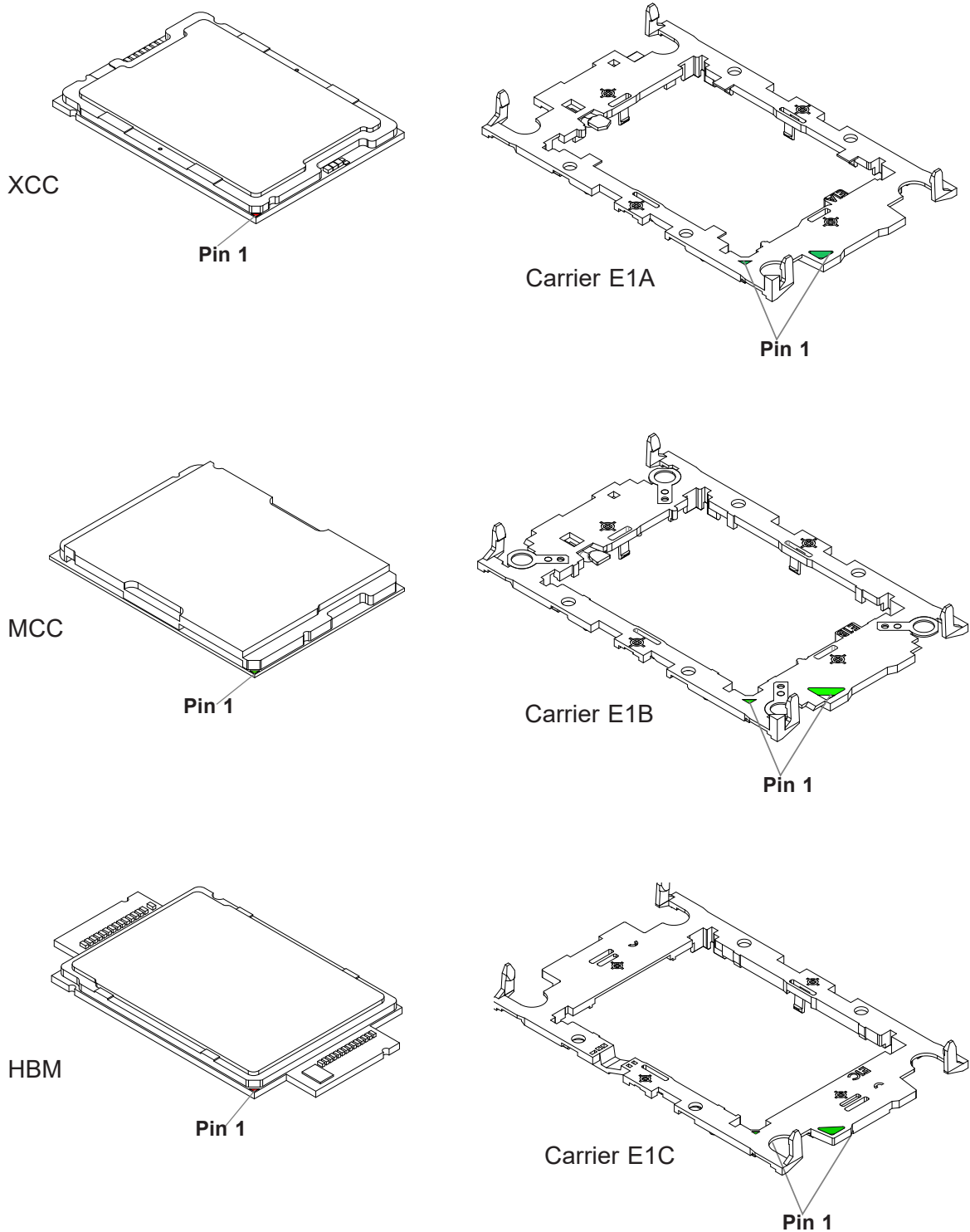

2. Turn the processor over (with the gold pins up). Locate the CPU keys on the processor and the four latches on the carrier.

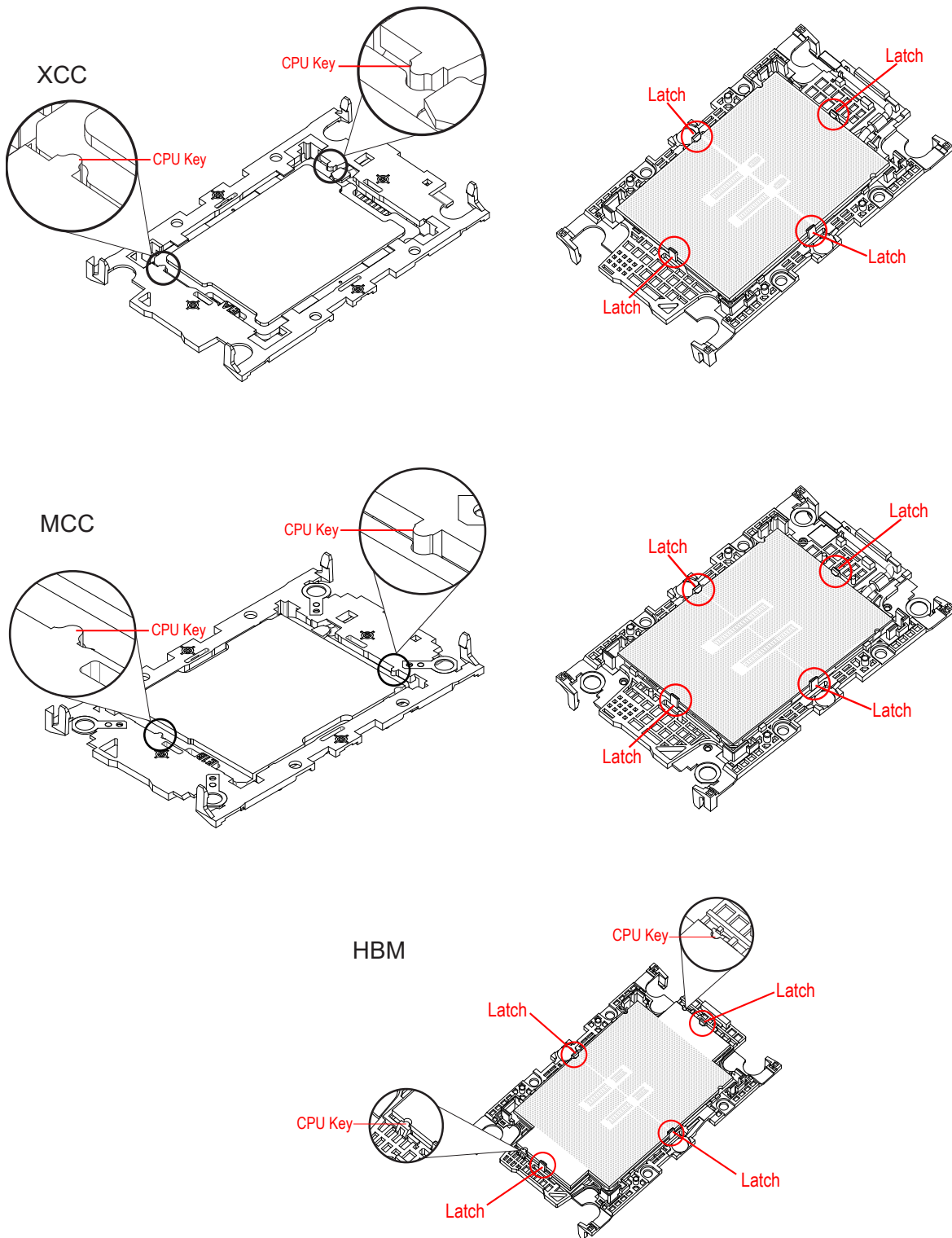

3. Locate the lever on the processor carrier and press it down (E1A and E1B only).

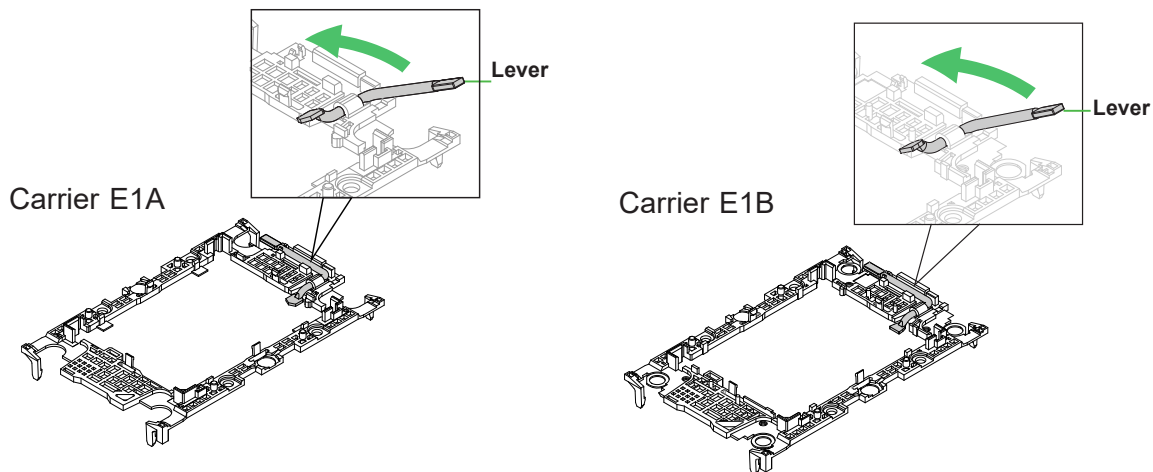

4. Using pin 1 as a guide, carefully align the CPU keys on the processor (A & B) with those on the carrier (a & b).

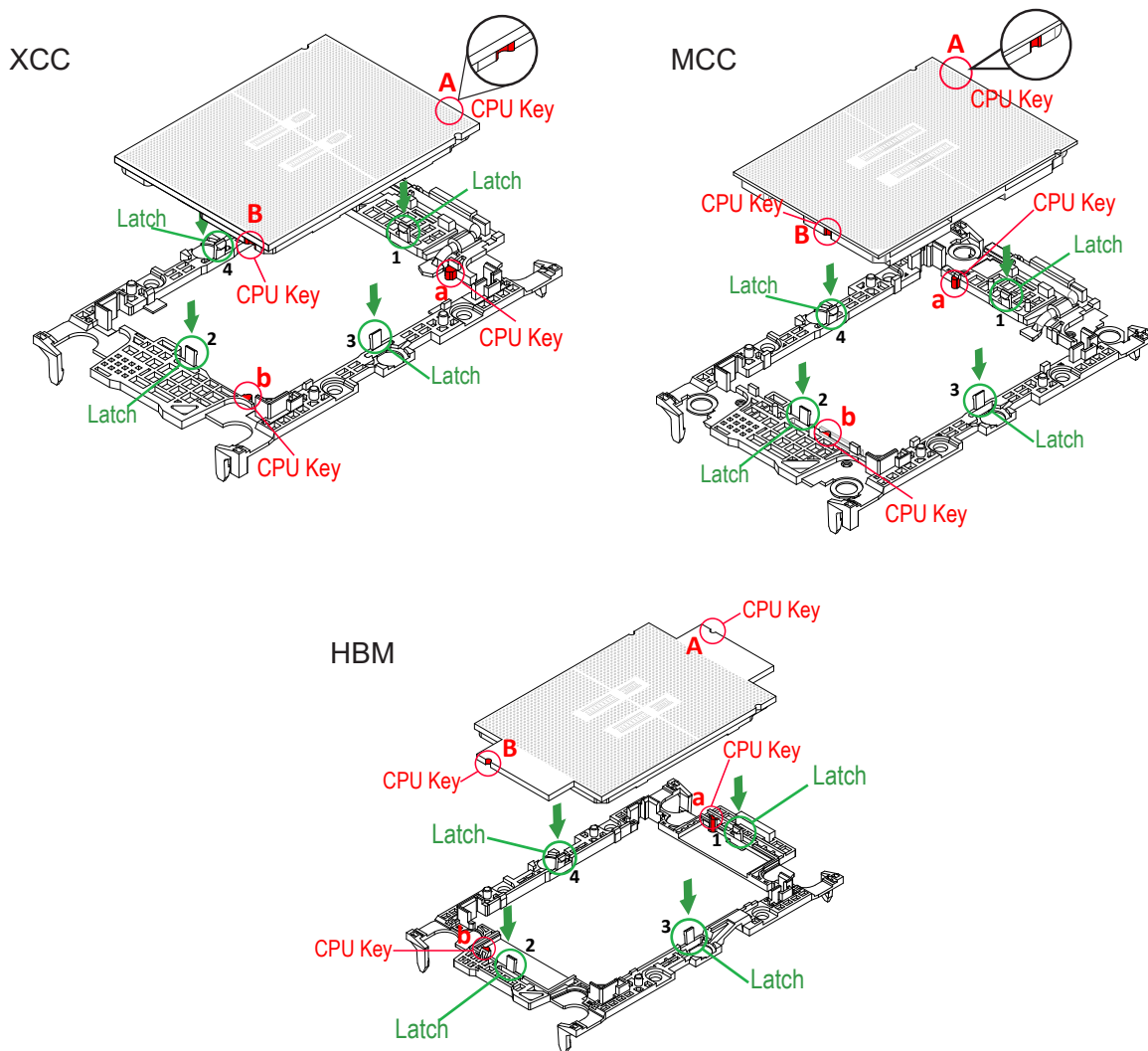

- Once aligned, carefully insert the CPU into the carrier, making sure that the CPU is secured by latches 1, 2, 3, and 4.

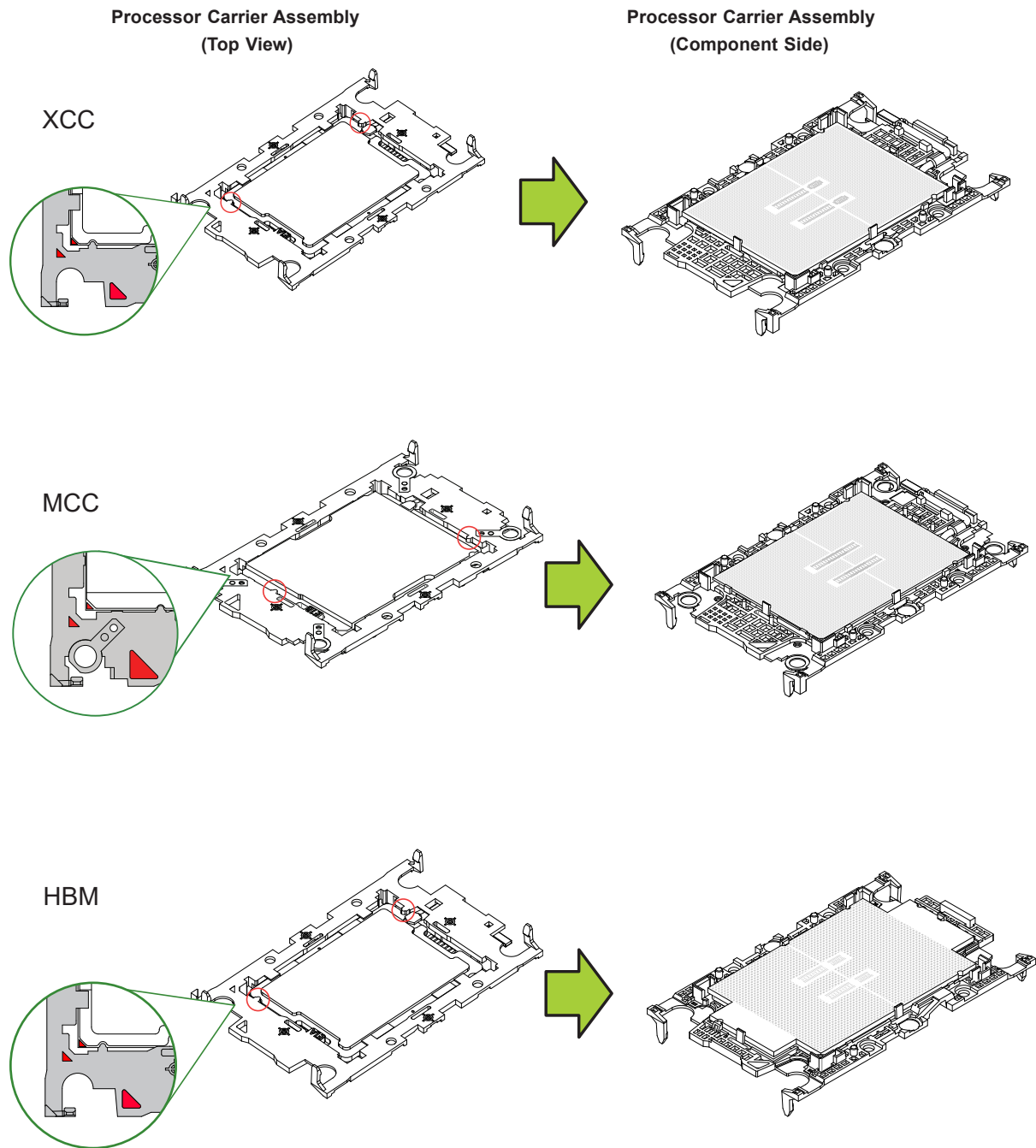

Assemble the Processor Heatsink Module

Thermal grease is pre-applied on a new heatsink. No additional thermal grease is needed. If this is a re-installation, apply the proper amount of thermal grease to the underside of the heatsink.

Assembling the Processor Heatsink Module (PHM)

1. Turn the heatsink over with the thermal grease facing up. Locate the two triangle cutouts (A, B) at the diagonal corners of the heatsink as shown in the drawing below.
2. Hold the processor carrier assembly component side up to locate the triangles on the processor and the carrier, which indicate pin 1.
3. Turn the processor carrier assembly over so that the gold pins are facing up, noting the two pin 1 locations ("A" on the processor and "a" on the processor carrier assembly).

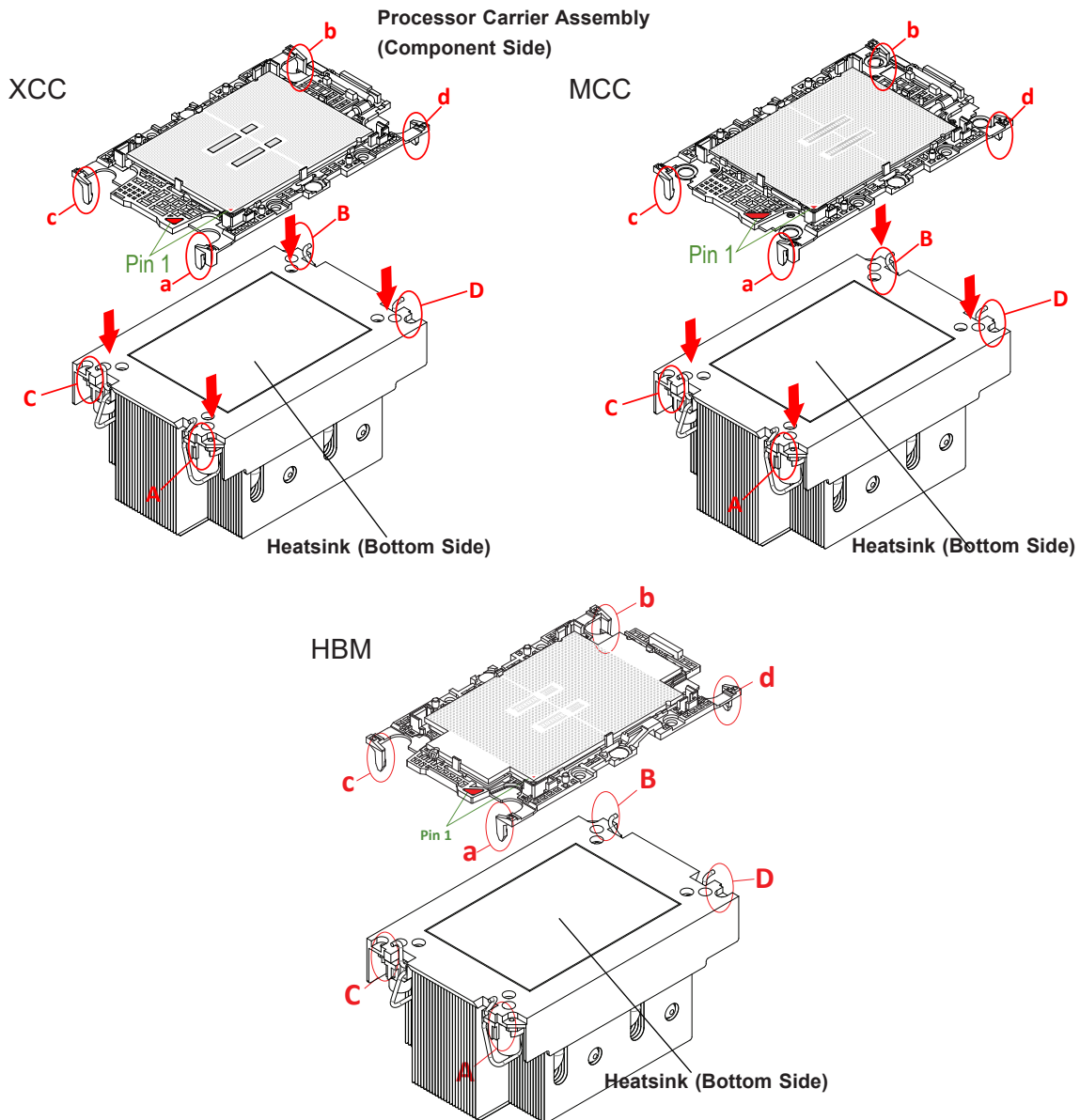

4. Align "a" on the processor carrier assembly with the triangular cutout "A" on the heatsink along with "b", "c", "d" on the processor assembly with "B", "C", "D" on the heatsink.
5. Once properly aligned, place the heatsink on the processor carrier assembly with all corners matched up, making sure that the four clips are properly securing the heatsink.

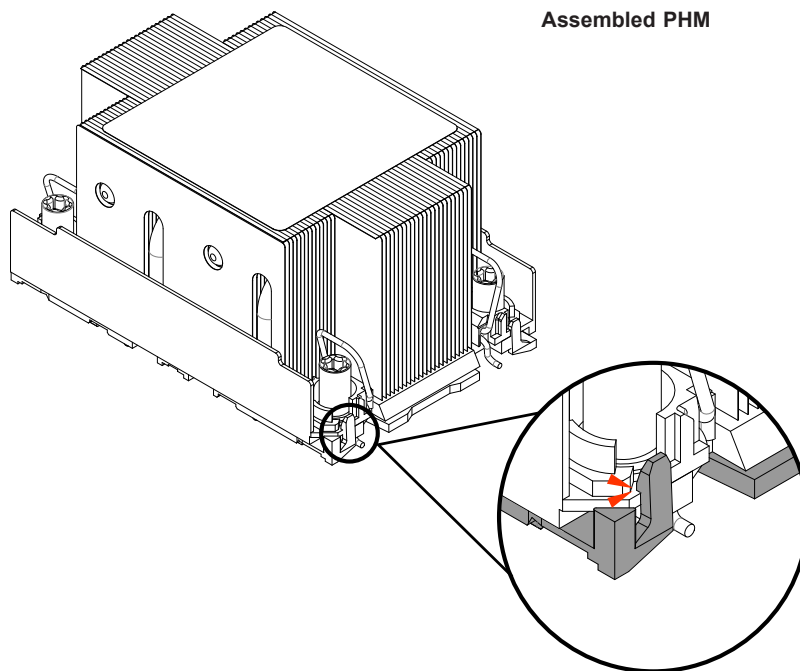

Note: The figure is for illustrative purposes. Your components may differ slightly from the components shown.

Remove the Socket Cover

Remove the plastic protective cover from the socket by gently squeezing the grip tabs and pulling the cover off.

CPU Socket with Plastic Protective Cover

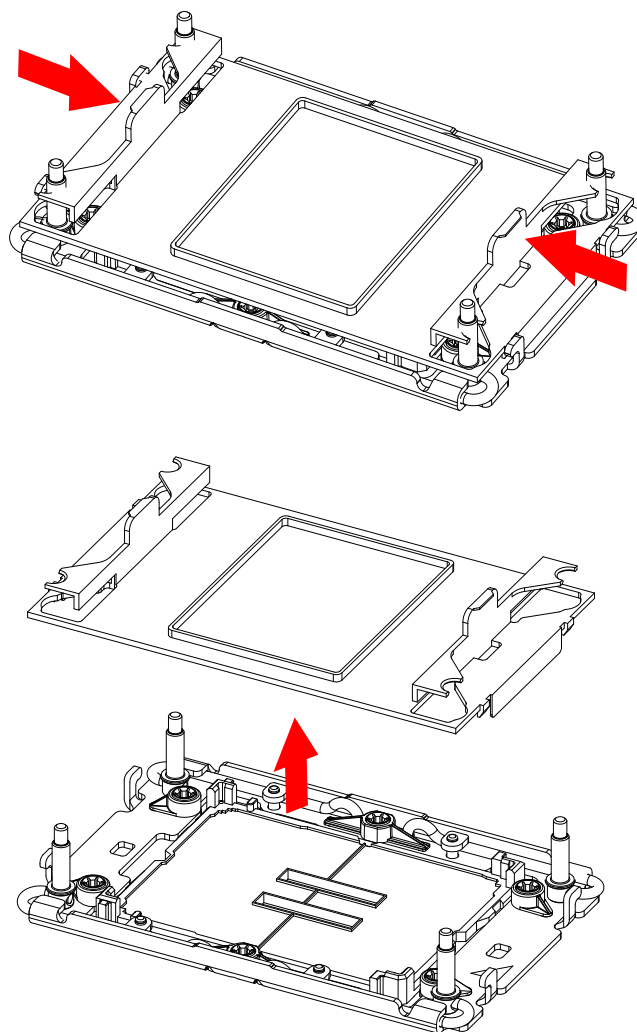

Install the PHM

To install the PHM into the CPU socket, follow these steps.

1. Locate four threaded fasteners (a, b, c, d) and Pin 1 on the CPU socket.

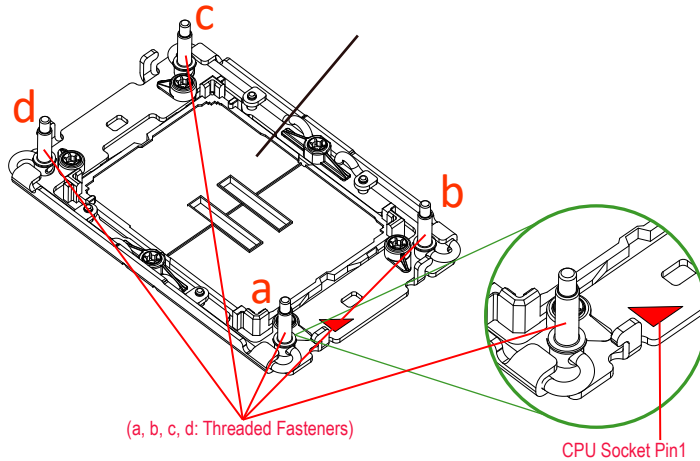

2. Locate four PEEK nuts (A, B, C, D) and four rotating wires (1, 2, 3, 4) on the heatsink.

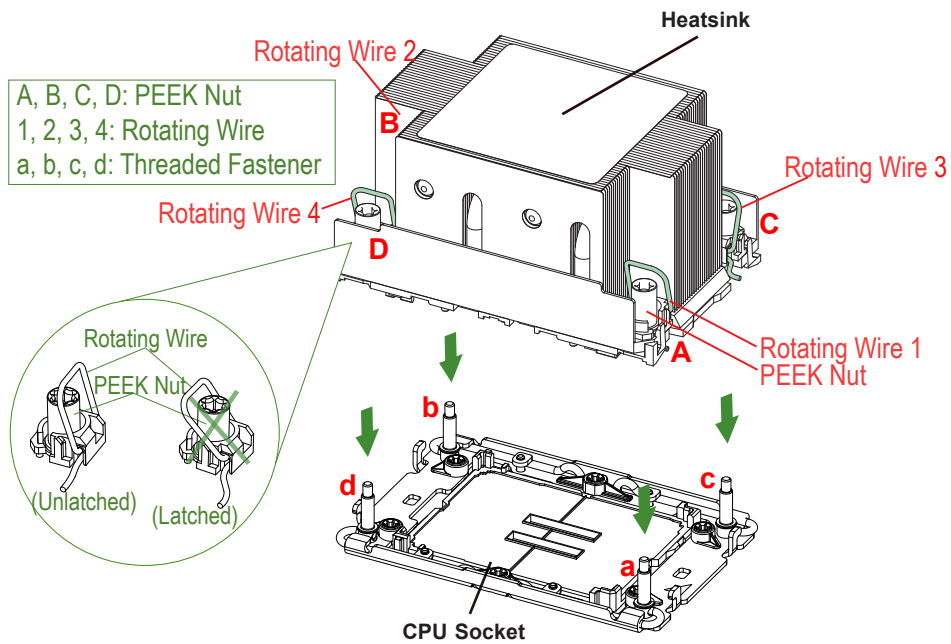

3. Check the rotating wires (1, 2, 3, 4) to make sure that they are in the unlatched position.

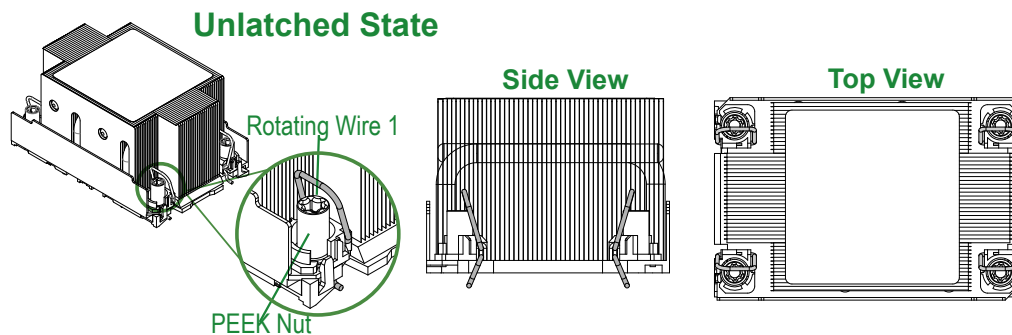

4. Align PEEK nut "A" (next to the triangular pin 1 on the heatsink) with threaded fastener "a" on the CPU socket. Then align PEEK nuts "B", "C", "D" on the heatsink with threaded fasteners "b", "c", "d" on the CPU socket.
5. Once aligned, gently place the PHM on the CPU socket, making sure that each PEEK nut is properly attached to its corresponding threaded fastener.

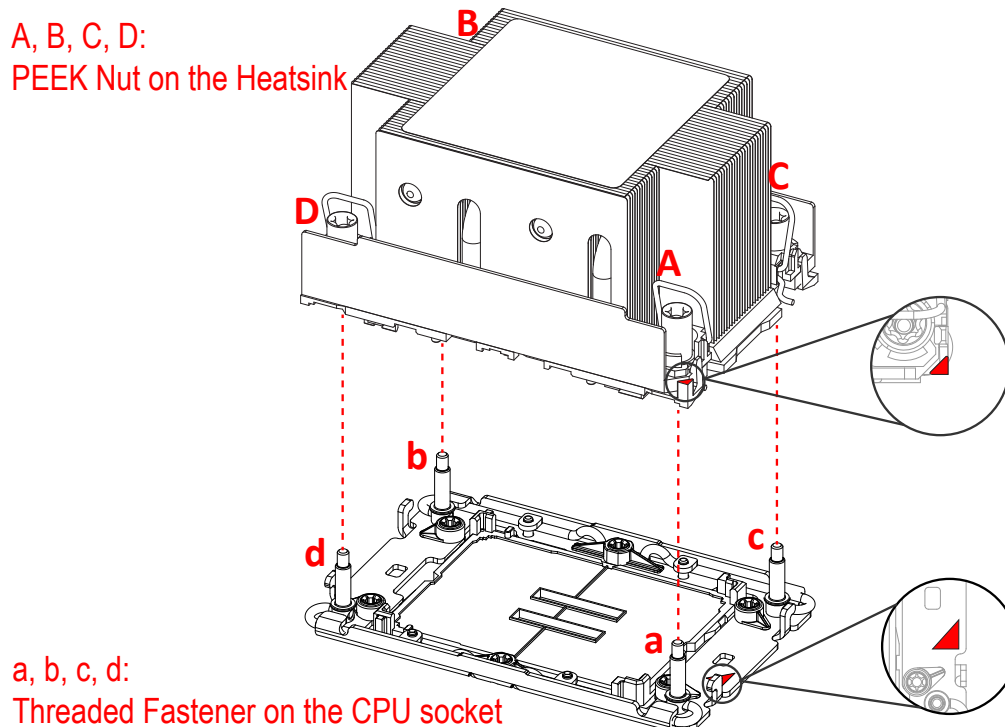

6. Press all four rotating wires outward and make sure that the heatsink is securely latched into the CPU socket.

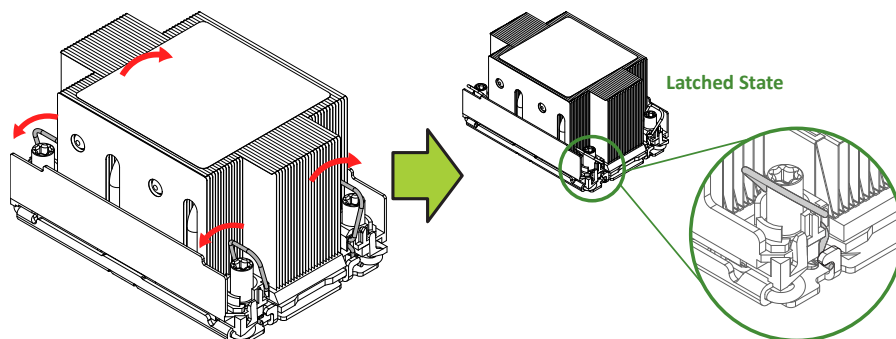

7. With a T30 bit torque driver set to a force of 8.0 in-lbf (0.904 N-m), tighten the PEEK nuts in the sequence of "A", "B", "C", and "D". Note the torque specifications written on the heatsink, and do not exceed them when tightening the screws.
8. Examine all corners of the heatsink to ensure that the PHM is firmly attached to the CPU socket.

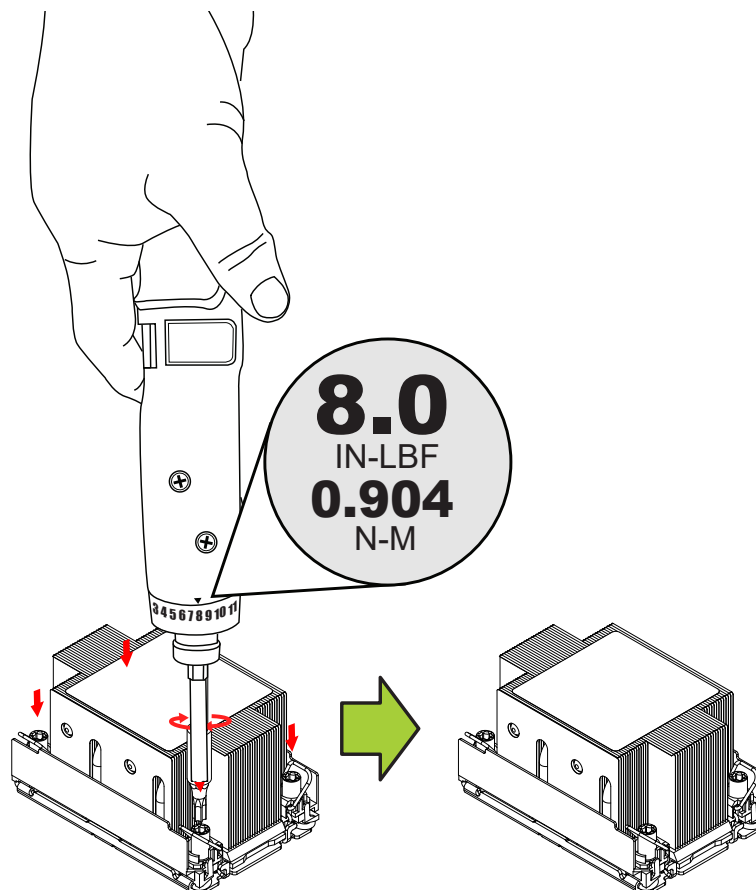

Removing the PHM

To remove the processor heatsink module (PHM) from the motherboard, follow these steps.

1. Shut down the system and unplug the AC power cord from all power supplies.
2. Use a T30-bit torque driver to loosen the four PEEK nuts on the heatsink in the sequence of A, B, C, and D.

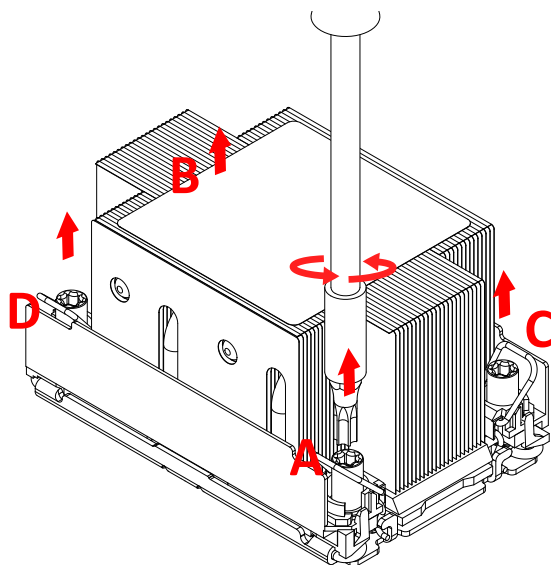

3. Press the rotating wires inward to unlatch the PHM from the socket as shown below.

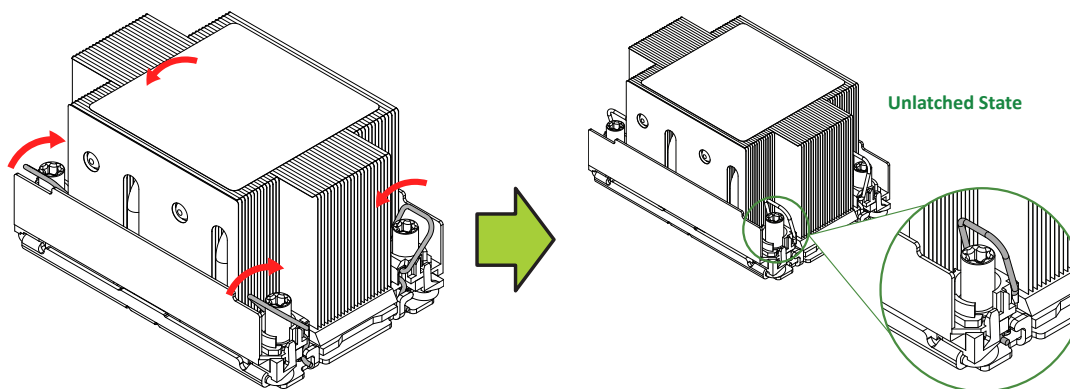

4. Gently lift the PHM upward to remove it from the CPU socket.

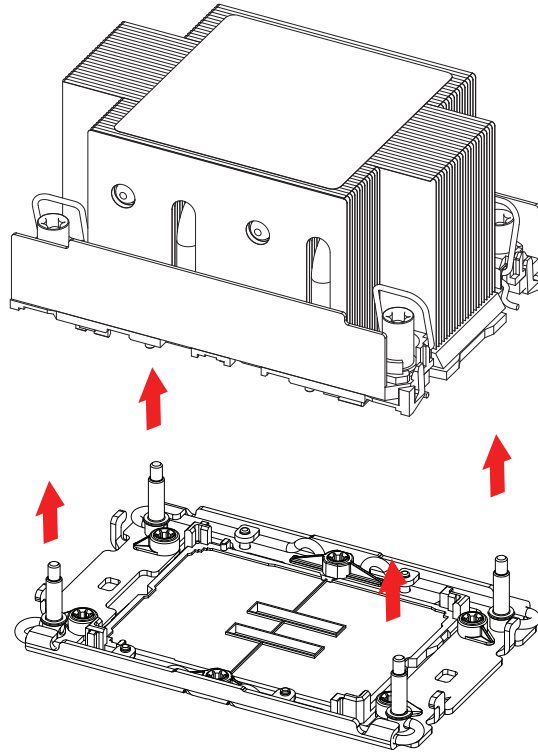

Removing the Carrier Assembly from the Heatsink

To remove the processor carrier assembly from the PHM, follow these steps:

1. Detach the four plastic clips (marked a, b, c, d) on the processor carrier assembly from the four corners of the heatsink (marked A, B, C, D) as shown below.

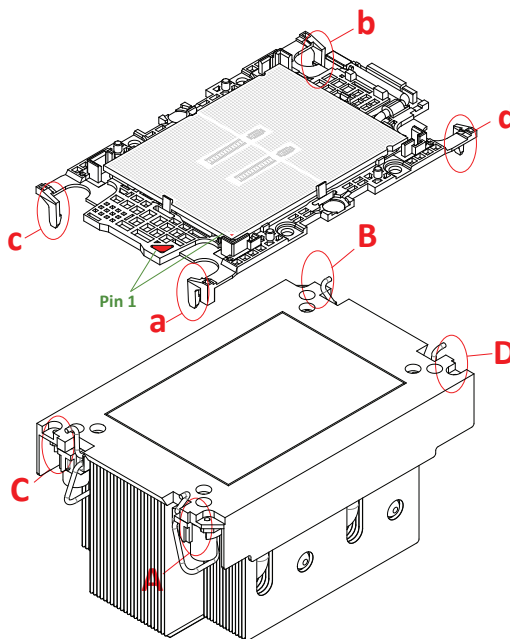

2. When all plastic clips have been detached from the heatsink, remove the processor carrier assembly from the heatsink

Removing the Processor from the Carrier Assembly

To remove the processor from the processor carrier, follow these steps.

1. Unlock the lever from its locked position and push it upwards to disengage the processor from the processor carrier as shown below right.

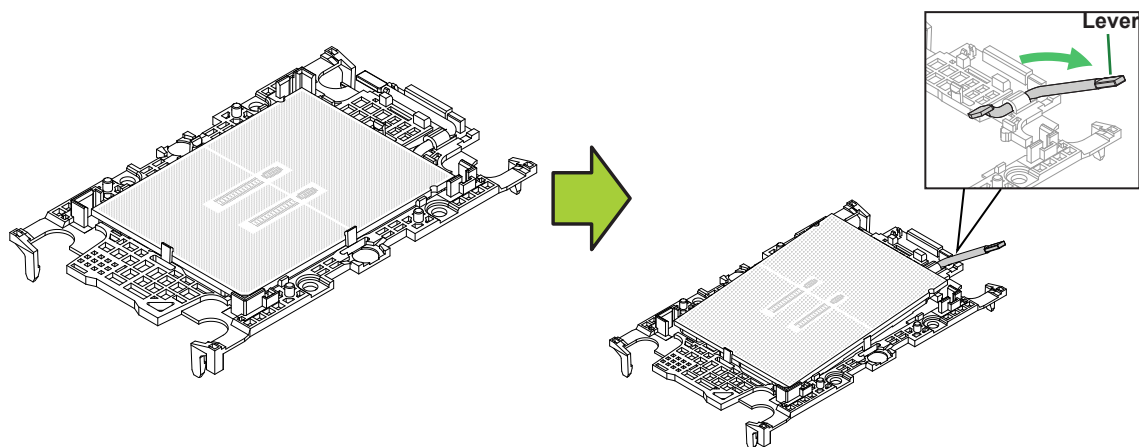

2. Once the processor has been loosened from the carrier, carefully remove the processor from the carrier.

Note: Handle the processor with care.

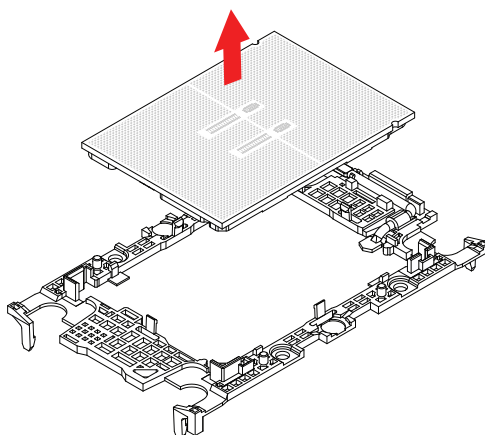

3.5 Memory Support and Installation

Note: Check the Supermicro website for recommended memory modules and updates on possible memory support.

Important: Exercise extreme care when installing or removing DIMM modules to prevent any possible damage.

Memory Support

This motherboard supports up to 8 TB 3DS RDIMM/RDIMM DDR5 (288-pin) ECC memory with speeds up to 5600 MT/s (1DPC) or 4400 MT/s (2DPC) in 32 DIMM configuration.

Note: Memory speed and capacity support depends on the processors used in the system. The 5th Gen. Xeon Scalable processors support DDR5 memory with speeds up to 5600MT/s (or up to 4400 MT/s in 32 DIMM configuration). The 4th Gen. Xeon Scalable processors support DDR5 memory with speeds up to 4800 MT/s (or up to 4400 MT/s in 32 DIMM configuration).

DDR5 Memory Support for 5th/4th Gen. Intel Xeon Scalable Processors

Key Parameters for DIMM Configurations	
Parameters	Possible Values
Number of Channels per Socket	1, 2, 4, 6, 8
Number of DIMMs per Channel	1DPC (1 DIMM Per Channel) or 2DPC (2 DIMMs Per Channel)
DIMM Type	RDIMM and 3DS RDIMM
DIMM Construction	non-3DS RDIMM Raw Cards: A (2Rx4), C (1Rx4), D (1Rx8), E (2Rx8) 3DS RDIMM Raw Cards: A (4Rx4, 8Rx4) 9x4 RDIMM Raw Cards: B (2Rx4), F (1Rx4)

DDR5 Memory Support for the 5 th Gen. Intel Xeon Scalable Processors					
Type	Ranks Per DIMM & Data Width (Stack)	DIMM Density and DIMM Capacity		Speed (MT/s); Voltage (V); DIMM Per Channel (DPC)	
				1DPC (Note)	2DPC
		16 Gb	24 Gb	1.1 V	
RDIMM	SRx8 (RC D)	16 GB	24 GB	5600	4400
	SRx4 (RC C)	32 GB	48 GB		
	SRx4 (RC F) 9x4	N/A	N/A		
	DRx8 (RC E)	32 GB	48 GB		
	DRx4 (RC A)	64 GB	96 GB		
	DRx4 (RC B) 9x4	N/A	N/A		
RDIMM 3DS	(4R/8R) x4 (RC A)	2H-128 GB 4H-256 GB	N/A	5600	
LRDIMM/LRDIMM-3DS	N/A	N/A	N/A	Not Supported	Not Supported

Note 1: 1DPC (1 DIMM Per Channel) applies to 1SPC (Sockets Per Channel) or 2SPC implementation.

Note 2: 24 Gb, 24 GB, and 48 GB DRAM capacity is not supported in 2DPC.

Note 3: Memory speed will be 5600 MT/s 1DPC or 4400 MT/s 2DPC.

Note 4: For 1DPC 5600 MT/s speed, DDR5-5600 DIMMs are required.

Note 5: Mixing DRAM densities (16 Gb/24 Gb) and/or frequencies is not allowed.

DDR5 Memory Support for the 4 th Gen. Intel Xeon Scalable Processors					
Type	Ranks Per DIMM & Data Width (Stack)	DIMM Density and DIMM Capacity		Speed (MT/s); Voltage (V); DIMM Per Channel (DPC)	
				1DPC (Note)	2DPC
		16 Gb	24 Gb	1.1 V	
RDIMM	SRx8 (RC D)	16 GB	24 GB	4800	4400
	SRx4 (RC C)	32 GB	48 GB		
	SRx4 (RC F) 9x4	32 GB	N/A		
	DRx8 (RC E)	32 GB	48 GB		
	DRx4 (RC A)	64 GB	96 GB		
	DRx4 (RC B) 9x4	64 GB	N/A		
RDIMM 3DS	(4R/8R) x4 (RC A)	2H-128 GB 4H-256 GB	N/A		
LRDIMM/LRDIMM-3DS	N/A	N/A	N/A	Not Supported	Not Supported

Note 1: 1DPC (1 DIMM Per Channel) applies to 1SPC (Sockets Per Channel) or 2SPC implementation.

Note 2: 24 Gb XCC only with limited configs: 1DPC all DIMM type, 2DPC 96 GB only. Only 8 and 16 DIMM configs, no fallbacks.

Note 3: Memory speed will be 4800 MT/s 1DPC or 4400 MT/s 2DPC.

Note 4: Mixing DRAM densities (16 Gb/24 Gb) and/or frequencies is not allowed.

Memory Population for the X13DEG-M Motherboard (with 32 DIMM Slots)

DDR5 Memory Population Table for the X13DEG-M Motherboard (with 32 DIMM Slots)	
1 CPU:	Memory Population Sequence
1 CPU & 1 DIMM	CPU1: P1-DIMMA1 or P1-DIMME1 or P1-DIMMB1 or P1-DIMMF1
1 CPU & 2 DIMMs	CPU1: P1-DIMMA1 / P1-DIMMG1 or P1-DIMMC1 / P1-DIMME1
1 CPU & 4 DIMMs	CPU1: P1-DIMMA1 / P1-DIMMC1 / P1-DIMME1 / P1-DIMMG1
1 CPU & 6 DIMM	CPU1: P1-DIMMA1 / P1-DIMMC1 / P1-DIMMD1 / P1-DIMME1 / P1-DIMMF1 / P1-DIMMG1 or CPU1: P1-DIMMA1 / P1-DIMMB1 / P1-DIMMC1 / P1-DIMME1 / P1-DIMMG1 / P1-DIMMH1 or CPU1: P1-DIMMA1 / P1-DIMMC1 / P1-DIMMD1 / P1-DIMME1 / P1-DIMMF1 / P1-DIMMH1 or CPU1: P1-DIMMA1 / P1-DIMMB1 / P1-DIMMD1 / P1-DIMMF1 / P1-DIMMG1 / P1-DIMMH1
1 CPU & 8 DIMMs	P1-DIMMA1 / P1-DIMMB1 / P1-DIMMC1 / P1-DIMMD1 / P1-DIMME1 / P1-DIMMF1 / P1-DIMMG1 / P1-DIMMH1
1 CPU & 12 DIMMs	CPU1: P1-DIMMA1 / P1-DIMMA2 / P1-DIMMB1 / P1-DIMMC1 / P1-DIMMC2 / P1-DIMMD1 / P1-DIMME1 / P1-DIMME2 / P1-DIMMF1 / P1-DIMMG1 / P1-DIMMG2 / P1-DIMMH1 or CPU1: P1-DIMMA1 / P1-DIMMB1 / P1-DIMMB2 / P1-DIMMC1 / P1-DIMMD1 / P1-DIMMD2 / P1-DIMME1 / P1-DIMMF1 / P1-DIMMF2 / P1-DIMMG1 / P1-DIMMH1 / P1-DIMMH2
1 CPU & 16 DIMMs	CPU1: P1-DIMMA1 / P1-DIMMA2 / P1-DIMMB1 / P1-DIMMB2 / P1-DIMMC1 / P1-DIMMC2 / P1-DIMMD1 / P1-DIMMD2 / P1-DIMME1 / P1-DIMME2 / P1-DIMMF1 / P1-DIMMF2 / P1-DIMMG1 / P1-DIMMG2 / P1-DIMMH1 / P1-DIMMH2
2 CPUs: (Recommended)	Memory Population Sequence
2 CPUs & 2 DIMMs	CPU1: P1-DIMMA1, CPU2: P2-DIMMA1 or CPU1: P1-DIMME1, CPU2: P2-DIMME1 or CPU1: P1-DIMMB1, CPU2: P2-DIMMB1 or CPU1: P1-DIMMF1, CPU2: P2-DIMMF1
2 CPUs & 4 DIMMs	CPU1: P1-DIMMA1 / P1-DIMMG1, CPU2: P2-DIMMA1 / P2-DIMMG1 or CPU1: P1-DIMMC1 / P1-DIMME1, CPU2: P2-DIMMC1 / P2-DIMME1
2 CPUs & 8 DIMMs	CPU1: P1-DIMMA1 / P1-DIMMC1 / P1-DIMME1 / P1-DIMMG1 CPU2: P2-DIMMA1 / P2-DIMMC1 / P2-DIMME1 / P2-DIMMG1
2 CPUs & 10 DIMMs	CPU1: P1-DIMMA1 / P1-DIMMC1 / P1-DIMMD1 / P1-DIMME1 / P1-DIMMF1 / P1-DIMMG1 CPU2: P2-DIMMA1 / P2-DIMMC1 / P2-DIMME1 / P2-DIMMG1
2 CPUs & 12 DIMMs	CPU1: P1-DIMMA1 / P1-DIMMC1 / P1-DIMMD1 / P1-DIMME1 / P1-DIMMF1 / P1-DIMMG1 CPU2: P2-DIMMA1 / P2-DIMMC1 / P2-DIMMD1 / P2-DIMME1 / P2-DIMMF1 / P2-DIMMG1 or CPU1: P1-DIMMA1 / P1-DIMMB1 / P1-DIMMC1 / P1-DIMME1 / P1-DIMMG1 / P1-DIMMH1 CPU2: P2-DIMMA1 / P2-DIMMB1 / P2-DIMMC1 / P2-DIMME1 / P2-DIMMG1 / P2-DIMMH1 or CPU1: P1-DIMMA1 / P1-DIMMB1 / P1-DIMMC1 / P1-DIMME1 / P1-DIMMG1 / P1-DIMMH1 CPU2: P2-DIMMA1 / P2-DIMMB1 / P2-DIMMC1 / P2-DIMME1 / P2-DIMMG1 / P2-DIMMH1 or CPU1: P1-DIMMA1 / P1-DIMMB1 / P1-DIMMD1 / P1-DIMMF1 / P1-DIMMG1 / P1-DIMMH1 CPU2: P2-DIMMA1 / P2-DIMMB1 / P2-DIMMD1 / P2-DIMMF1 / P2-DIMMG1 / P2-DIMMH1
2 CPUs & 16 DIMMs	CPU1: P1-DIMMA1 / P1-DIMMB1 / P1-DIMMC1 / P1-DIMMD1 / P1-DIMME1 / P1-DIMMF1 / P1-DIMMG1 / P1-DIMMH1 CPU2: P2-DIMMA1 / P2-DIMMB1 / P2-DIMMC1 / P2-DIMMD1 / P2-DIMME1 / P2-DIMMF1 / P2-DIMMG1 / P2-DIMMH1
2 CPUs & 22 DIMMs	CPU1: P1-DIMMA1 / P1-DIMMA2 / P1-DIMMB1 / P1-DIMMB2 / P1-DIMMC1 / P1-DIMMC2 / P1-DIMMD1 / P1-DIMMD2 / P1-DIMME1 / P1-DIMME2 / P1-DIMMF1 / P1-DIMMF2 / P1-DIMMG1 / P1-DIMMG2 / P1-DIMMH1 / P1-DIMMH2 CPU2: P2-DIMMA1 / P2-DIMMC1 / P2-DIMMD1 / P2-DIMME1 / P2-DIMMF1 / P2-DIMMG1
2 CPUs & 24 DIMMs	CPU1: P1-DIMMA1 / P1-DIMMA2 / P1-DIMMB1 / P1-DIMMB2 / P1-DIMMC1 / P1-DIMMC2 / P1-DIMMD1 / P1-DIMMD2 / P1-DIMME1 / P1-DIMME2 / P1-DIMMF1 / P1-DIMMF2 / P1-DIMMG1 / P1-DIMMG2 / P1-DIMMH1 / P1-DIMMH2 CPU2: P2-DIMMA1 / P2-DIMMB1 / P2-DIMMC1 / P2-DIMMD1 / P2-DIMME1 / P2-DIMMF1 / P2-DIMMG1 / P2-DIMMH1
2 CPUs & 32 DIMMs	CPU1: P1-DIMMA1 / P1-DIMMA2 / P1-DIMMB1 / P1-DIMMB2 / P1-DIMMC1 / P1-DIMMC2 / P1-DIMMD1 / P1-DIMMD2 / P1-DIMME1 / P1-DIMME2 / P1-DIMMF1 / P1-DIMMF2 / P1-DIMMG1 / P1-DIMMG2 / P1-DIMMH1 / P1-DIMMH2 CPU2: P2-DIMMA1 / P2-DIMMA2 / P2-DIMMB1 / P2-DIMMB2 / P2-DIMMC1 / P2-DIMMC2 / P2-DIMMD1 / P2-DIMMD2 / P2-DIMME1 / P2-DIMME2 / P2-DIMMF1 / P2-DIMMF2 / P2-DIMMG1 / P2-DIMMG2 / P2-DIMMH1 / P2-DIMMH2

Note: This memory configuration is recommended by Supermicro for optimal memory performance. Please use this configuration to maximize your memory performance.

DDR5 Memory Population Table for HMB CPU 32-DIMM Motherboards	
1 CPU:	Memory Population Sequence
1 CPU & 1 DIMM	P1-DIMMA1 or P1-DIMME1
1 CPU & 2 DIMMs	P1-DIMMA1 / P1-DIMMG1 or P1-DIMMC1 / P1-DIMME1
1 CPU & 4 DIMMs	P1-DIMMA1 / P1-DIMMC1 / P1-DIMME1 / P1-DIMMG1
1 CPU & 8 DIMMs	P1-DIMMA1/P1-DIMMB1 / P1-DIMMC1 / P1-DIMMD1 / P1-DIMME1 / P1-DIMMF1 / P1-DIMMG1 / P1-DIMMH1
1 CPU & 16 DIMMs	P1-DIMMA1 / P1-DIMMA2 / P1-DIMMB1 / P1-DIMMB2 / P1-DIMMC1 / P1-DIMMC2 / P1-DIMMD1 / P1-DIMMD2 / P1-DIMME1 / P1-DIMME2 / P1-DIMMF1 / P1-DIMMF2 / P1-DIMMG1 / P1-DIMMG2 / P1-DIMMH1 / P1-DIMMH2
2 CPUs: (Recommended)	Memory Population Sequence
2 CPUs & 2 DIMMs	CPU1: P1-DIMMA1, CPU2: P2-DIMMA1 or CPU1: P1-DIMME1, CPU2: P2-DIMME1
2 CPUs & 4 DIMMs	CPU1: P1-DIMMA1 / P1-DIMMG1, CPU2: P2-DIMMA1 / P2-DIMMG1 or CPU1: P1-DIMMC1 / P1-DIMME1, CPU2: P2-DIMMC1 / P2-DIMME1
2 CPUs & 8 DIMMs	CPU1: P1-DIMMA1 / P1-DIMMC1 / P1-DIMME1 / P1-DIMMG1 or CPU2: P2-DIMMA1 / P2-DIMMC1 / P2-DIMME1 / P2-DIMMG1
2 CPUs & 16 DIMMs	CPU1: P1-DIMMA1 / P1-DIMMB1 / P1-DIMMC1 / P1-DIMMD1 / P1-DIMME1 / P1-DIMMF1 / P1-DIMMG1 / P1-DIMMH1 or CPU2: P2-DIMMA1 / P2-DIMMB1 / P2-DIMMC1 / P2-DIMMD1 / P2-DIMME1 / P2-DIMMF1 / P2-DIMMG1 / P2-DIMMH1
2 CPUs & 32 DIMMs	CPU1: P1-DIMMA1 / P1-DIMMA2 / P1-DIMMB1 / P1-DIMMB2 / P1-DIMMC1 / P1-DIMMC2 / P1-DIMMD1 / P1-DIMMD2 / P1-DIMME1 / P1-DIMME2 / P1-DIMMF1 / P1-DIMMF2 / P1-DIMMG1 / P1-DIMMG2 / P1-DIMMH1 / P1-DIMMH2 CPU2: P2-DIMMA1 / P2-DIMMA2 / P2-DIMMB1 / P2-DIMMB2 / P2-DIMMC1 / P2-DIMMC2 / P2-DIMMD1 / P2-DIMMD2 / P2-DIMME1 / P2-DIMME2 / P2-DIMMF1 / P2-DIMMF2 / P2-DIMMG1 / P2-DIMMG2 / P2-DIMMH1 / P2-DIMMH2

Notes:

- Max Series (HBM) processors support 1DPC (4800 MT/s) / 2DPC (4400 MT/s) to optimize the memory bandwidth. Max Series (HBM) processors support 1, 2, 4, 8, or 16 DIMMs in Flat Mode and Cache Mode, and 0 DIMMs in HBM-Only mode. HBM-Only mode runs exclusively using HBM memory.
- For the best memory performance in Flat mode and Cache mode, please use 4, 8, or 16 DIMM configurations. (At least one DIMM per memory controller for balanced configuration)
 - 4 DIMMs -> populate 1 DIMM/iMC
 - 8 DIMMs -> populate 1 DIMM/Channel, 2 DIMM/iMC
 - 16 DIMMs -> populate 2 DIMM/Channel, 4 DIMM/iMC
- All other configurations not listed above are not supported.
- For a dual-socket design, each socket has to be populated identically.

Memory Slots

This motherboard supports up to 8 TB of DDR5 memory in 32 slots. Please refer to the layout drawing below for the locations of the DIMM slots:

DIMM Slots Supported by CPU1	DIMM Slots Supported by CPU2
P1-DIMMA1	P2-DIMMA1
P1-DIMMA2	P2-DIMMA2
P1-DIMMB1	P2-DIMMB1
P1-DIMMB2	P2-DIMMB2
P1-DIMMC1	P2-DIMMC1
P1-DIMMC2	P2-DIMMC2
P1-DIMMD1	P2-DIMMD1
P1-DIMMD2	P2-DIMMD2
P1-DIMME1	P2-DIMME1
P1-DIMME2	P2-DIMME2
P1-DIMMF1	P2-DIMMF1
P1-DIMMF2	P2-DIMMF2
P1-DIMMG1	P2-DIMMG1
P1-DIMMG2	P2-DIMMG2
P1-DIMMH1	P2-DIMMH1
P1-DIMMH2	P2-DIMMH2

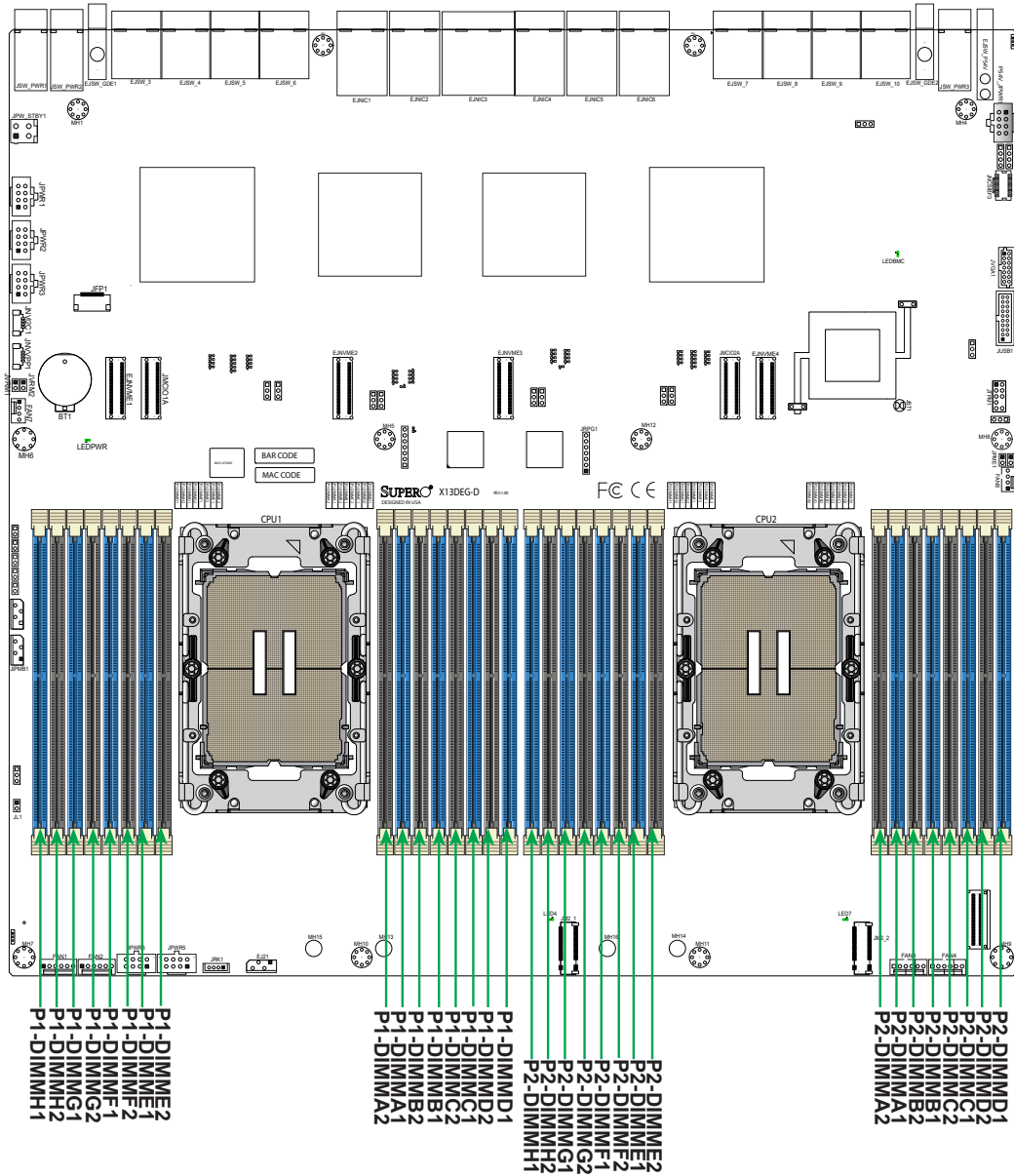
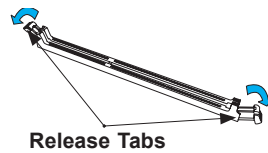

Figure 3-6. DIMM Numbering

DIMM Installation

Note: The DDR5 DIMM modules are **NOT** hot-swap; be sure to disconnect power for a minimum of 20 seconds before inserting or removing DIMMs.

1. Insert the desired number of DIMMs into the memory slots based on the recommended DIMM population tables in the previous section. Locate DIMM memory slots on the motherboard as shown on the right.



2. Push the release tabs outwards on both ends of the DIMM slot to unlock it.

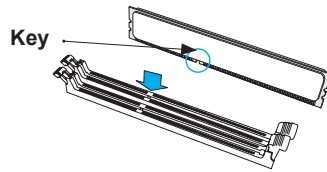

3. Align the key of the memory module with the DIMM socket key on the memory slot.

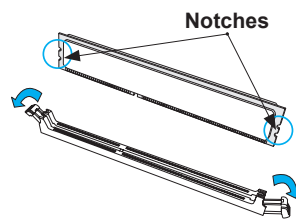

4. Align the notches on both ends of the module against the latches on the ends of the slot.
5. Push both ends of the module straight down into the slot until the module snaps into place.
6. Press the release tabs to the lock positions to secure the memory module into the slot.

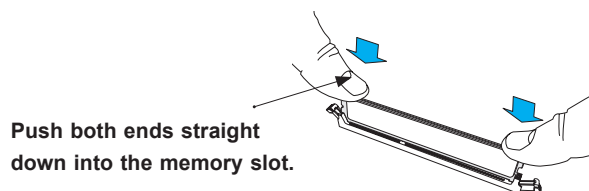

DIMM Removal

Press both release tabs on the ends of the memory module to unlock it. Once the memory module has been loosened, remove it from the memory slot.

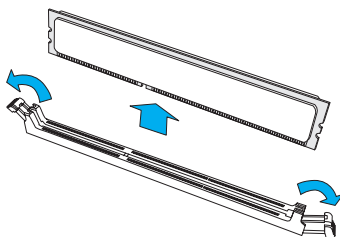

Note: Removing a DDR5 DIMM module at a slant angle will cause module damages. It is strongly recommended that you lift the module straight up out of the slot.

Important! Please do not use excessive force when pressing the release tabs on the ends of the DIMM socket to avoid causing any damage to the memory module or the DIMM socket. Please handle memory modules with care. Carefully follow all the instructions given on page 24 to avoid ESD-related damages done to your memory modules or components.

3.7 Motherboard Battery Removal and Installation

Battery Removal

To remove the onboard battery, follow the steps below.

1. Power off your system and unplug your power cable.
2. Place the system on a workbench.
3. Remove the top cover from the system.
4. Locate the onboard battery as shown below.
5. Using a tool such as a pen or a small screwdriver, push the battery lock outwards to unlock it. Once unlocked, the battery will pop out of the holder.
6. Remove the battery.

Proper Battery Disposal

Important: Handle used batteries carefully. Do not damage the battery in any way; a damaged battery may release hazardous materials into the environment. Do not discard a used battery in the garbage or a public landfill. Please comply with the regulations set up by your local hazardous waste management agency to dispose of your used battery properly.

Battery Installation

To install the onboard battery, follow the steps 1 and 2 below.

Important: When replacing a battery, be sure to only replace it with the same type.

1. Identify the battery's polarity. The positive (+) side should be facing up.
2. Insert the battery into the battery holder and push it down until you hear a click to ensure that the battery is securely locked.

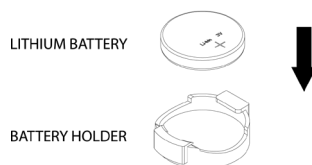

Figure 3-7. Installing a Battery

3.6 Storage Drives

The SYS-A21GE-NBRT system supports ten 2.5" form-factor NVMe SSD drives and two M.2 drives via two slots on the motherboard.

Note: Enterprise level storage drives are recommended for use in Supermicro servers. For compatible storage drives, see the [system web page](#).

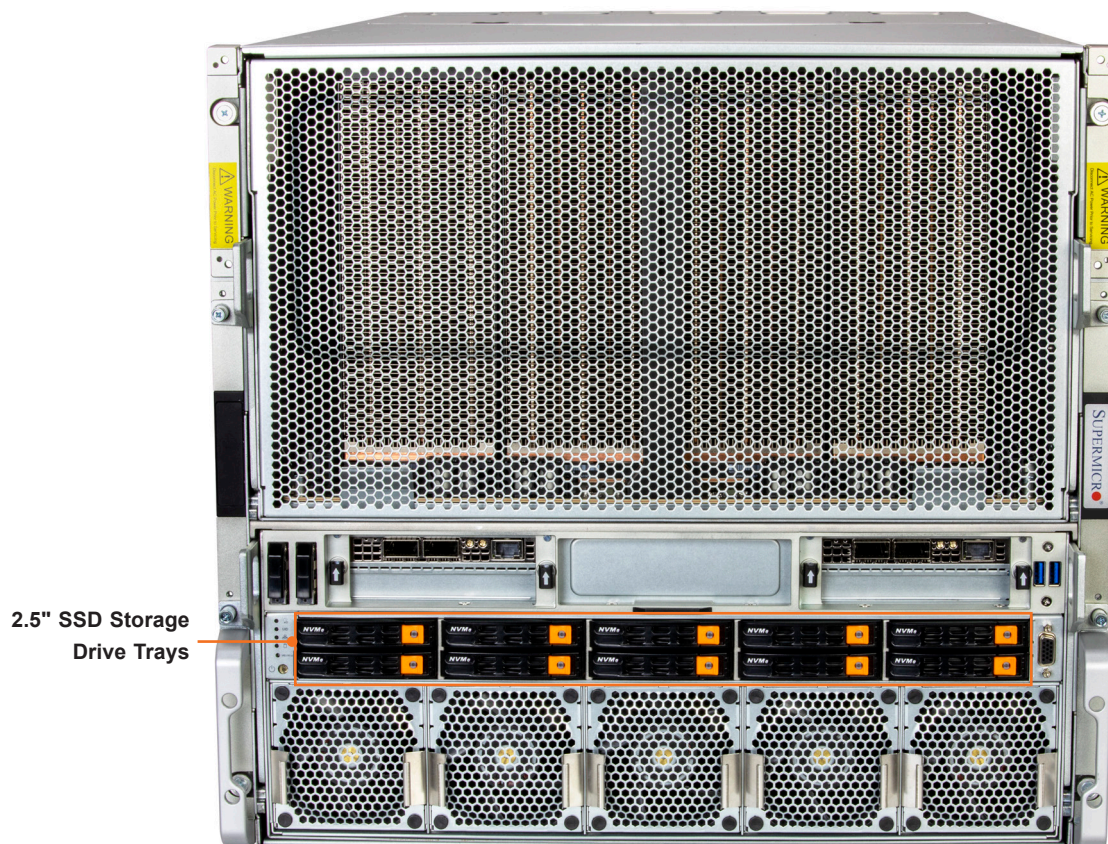

Figure 3-8. Locations of System Storage Devices

2.5" NVMe SSDs

There are 10 trays for 2.5" SSDs in the chassis. All 10 drive bays support NVMe drives. The drives are mounted in drive carriers that simplify their removal from the chassis.

Note: All carriers should be installed, regardless of whether they contain storage devices, to maintain proper airflow throughout the entire server.

Installing 2.5" SSDs

1. Remove the drive carrier from the chassis. Push the release button on the drive carrier. This releases and extends the drive carrier handle. If the button does not release it, the handle may be locked. Using a flat-head screwdriver, rotate the screw counterclockwise 45 degrees to unlock the handle. Use the handle to pull the carrier out of the chassis.

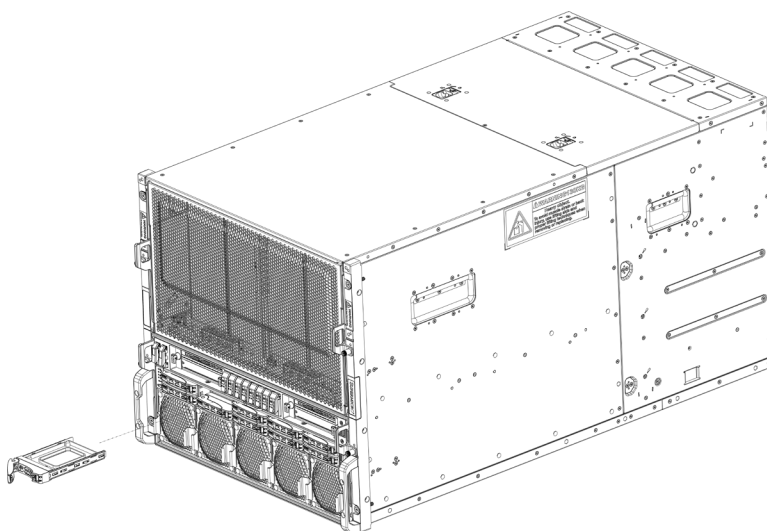

Figure 3-9. Removing a Drive Carrier

2. Insert the drive into the drive carrier and secure the drive to the carrier, as shown below. Orient the drive with the connector facing the bottom rear of the carrier. The drive can be inserted from above the carrier and into the clips until a "click" is heard.

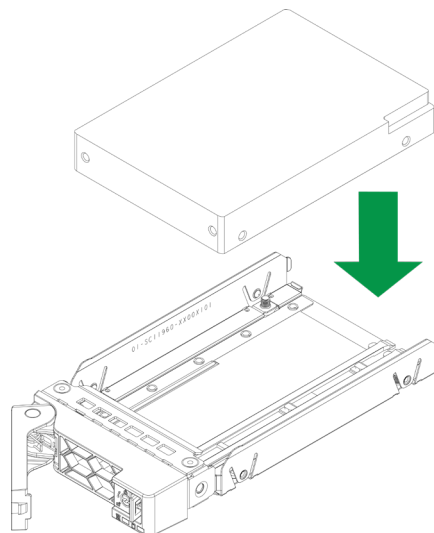

Figure 3-10. Placing a 2.5" Storage Drive into the Drive Carrier

3. Secure the storage drive on to the carrier with bottom screws, if needed.
4. Insert the carrier with the storage drive into the open drive bay.

Note: Enterprise level drives are recommended for use in Supermicro chassis and servers. For information on recommended storage drives, visit the Supermicro website product pages at www.supermicro.com/products.

Checking the Temperature of an NVMe Drive

There are two ways to check using the BMC Dashboard.

Checking a Drive

- **BMC Dashboard > Server Health > NVMe SSD** – Shows the temperatures of all NVMe drives.
- **BMC Dashboard > Server Health > Sensor Reading > NVME_SSD** – Shows the single highest temperature among all the NVMe drives.

3.7 System Cooling

Multiple 8-cm fans provide the cooling for the system. Fans may be replaced while the system continues to operate. Cooling is aided by louvers in the chassis that help prevent expelled hot air from returning into the chassis.

Notes: Make sure there are no objects to obstruct air flow in and out of the server.

Make sure no wires or foreign objects obstruct air flow through the chassis. Pull all excess cabling out of the airflow path or use shorter cables.

Changing a System Fan

1. Determine which fan is failing. If possible, use the BMC.
2. Squeeze the release tabs on each side of the fan together and pull the fan out.

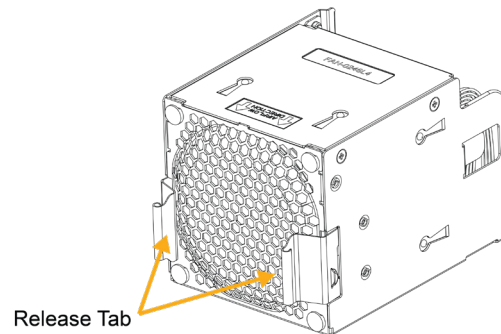

Figure 3-11. Releasing a Fan

3. Place the replacement fan into the vacant space. Push until the latches click and the fan is secure.

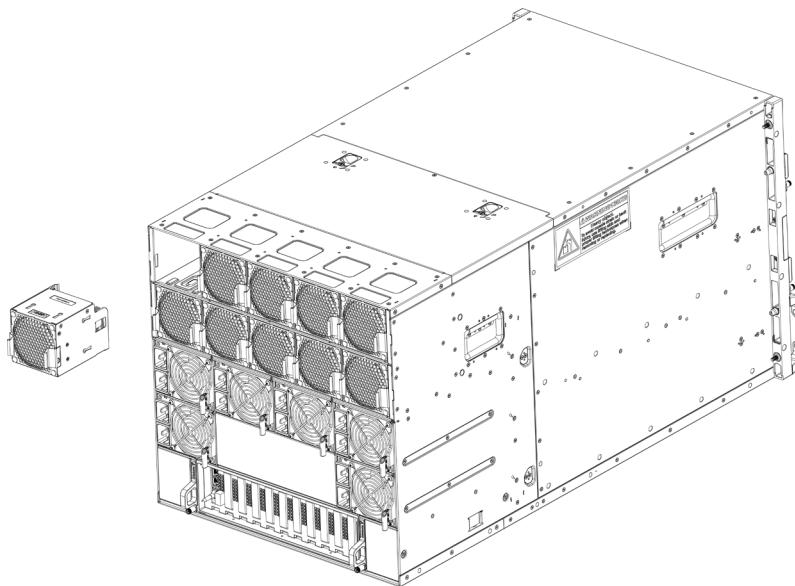

Figure 3-12. Installing a New Fan into the Drive Tray

Air Shrouds

The system requires air shrouds for each drawer, it needs it to maximize airflow efficiency. The motherboard, any expansion cards, and all components must be installed in the chassis. Place the air shroud as pictured.

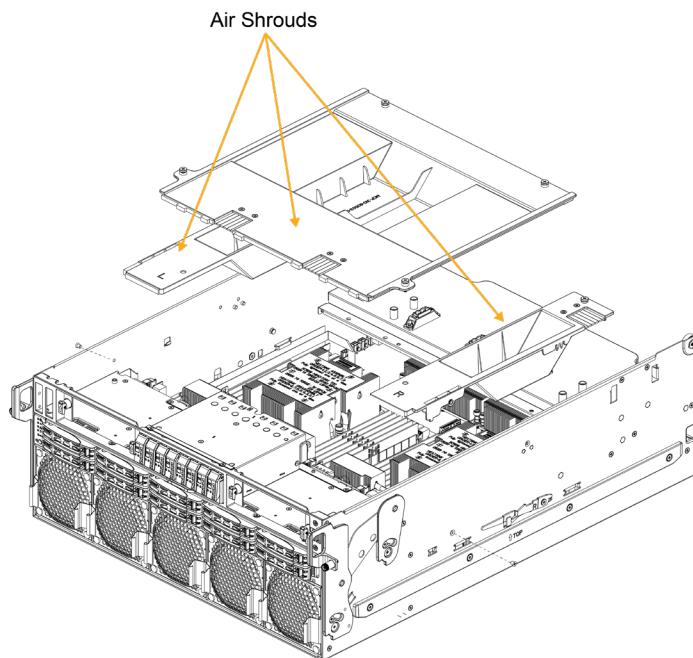

Figure 3-13. Installing the CPU Drawer Air Shroud

1. First, ensure the CPU, CPU heatsinks, and configured DIMMs are installed.
2. Align the air shroud with the motherboard.
3. Install directly onto the motherboard. Tighten the four screws on the top of the air shroud and two on the air shroud sides.

3.8 Expansion Cards

The default system can accommodate eight low-profile and two FHHL PCIe cards.

Low-Profile PCIe Cards

LPIO Drawer

The LPIO drawer is located in the rear of the chassis along with the system fans and power supplies. Removing the drawer is as simple as unlocking two levers and pulling out the drawer. For information on removing the LPIO drawer see "Accessing the System".

Installing Low-Profile PCIe Cards

1. Insert the PCIe card directly into a slot.
2. Secure with the provided screw.
3. Slide the LPIO drawer back into the chassis.
4. Lock using the locking levers.

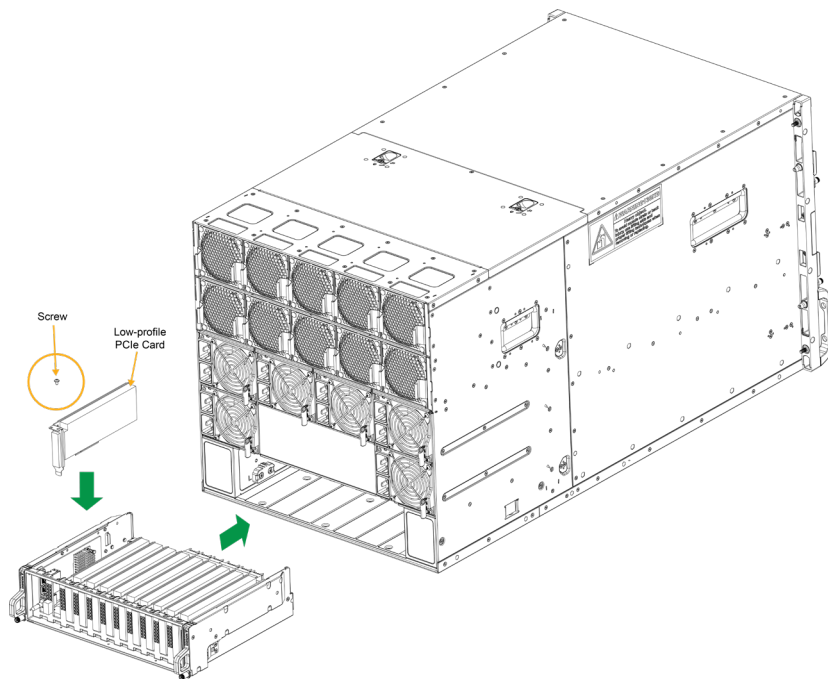

Figure 3-14. Installing Low-Profile PCIe Cards

Risers and I/O Cards

The CPU drawer has a total of four PCIe slots per system that are supported by riser cards. These slots are most often used to house I/O devices such as network interface cards and host adapters to connect to other servers.

Removing the Riser Cards

The riser cards where the PCIe cards are installed may be removed from the CPU drawer.

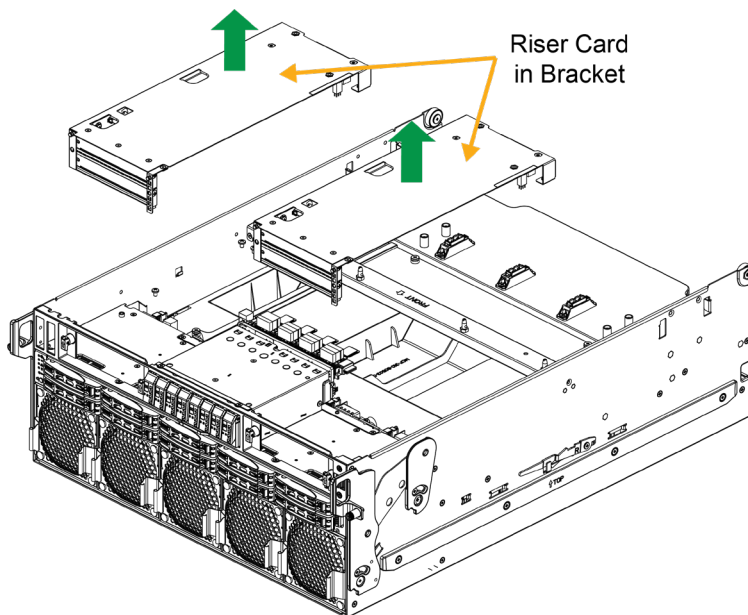

Figure 3-15. BF3 Riser Bracket with the Riser Card

Installing Front Riser Cards

An exploded view of the riser card in relation to the BF3 riser bracket is shown below.

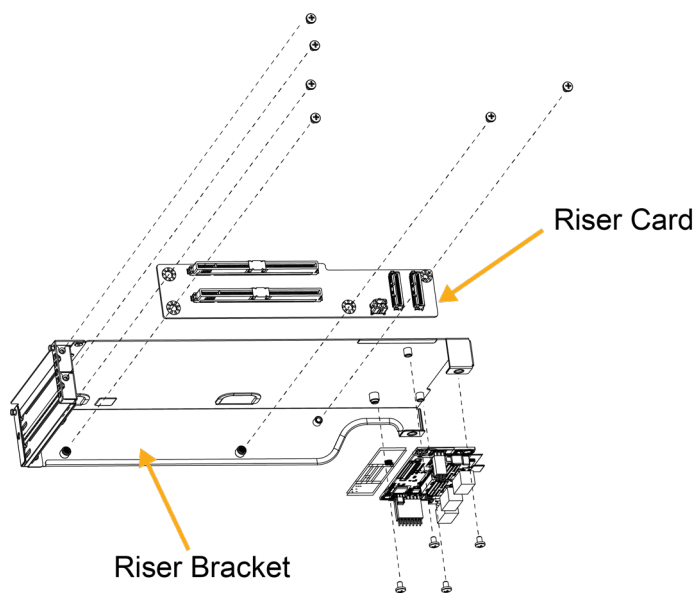

Figure 3-16. Exploded View of the Riser Card

3.9 Power Supply

The SYS-A21GE-NBRT includes six hot-plug power supply modules. These modules will automatically sense and operate at an input voltage between 100–240 V. Note that different input voltages will result in different maximum power output levels.

In the event of a power module failure, the other power module will continue to power the system on its own. Failed power supply modules can be replaced without powering down the system. Replacement modules can be ordered directly from Supermicro.

Power Supply Indicators		
Power Supply Condition	Green LED	Amber LED
No AC power to power supply	Off	Off
Power supply critical events causing a shutdown/failure/OCP/OVP/Fan Fail/OTP/UVP	Off	On
Power supply warning events where the power supply continues to operate; high temperature; over voltage; under voltage, etc.	Off	1 Hz Blinking
AC present only 12 VSB On (power supply off)	1 Hz Blinking	Off
Output ON and OK	On	Off
AC cord unplugged and in redundant mode	Off	On

Replacing the Power Supply

1. Unplug the AC power cord from the failed power supply module.
2. Push and hold the release tab on the back of the power supply.
3. Grasp the handle of the power supply and pull it out of its bay.
4. Push the new power supply module into the power bay until it clicks into the locked position.
5. Plug the AC power cord back into the power supply module.

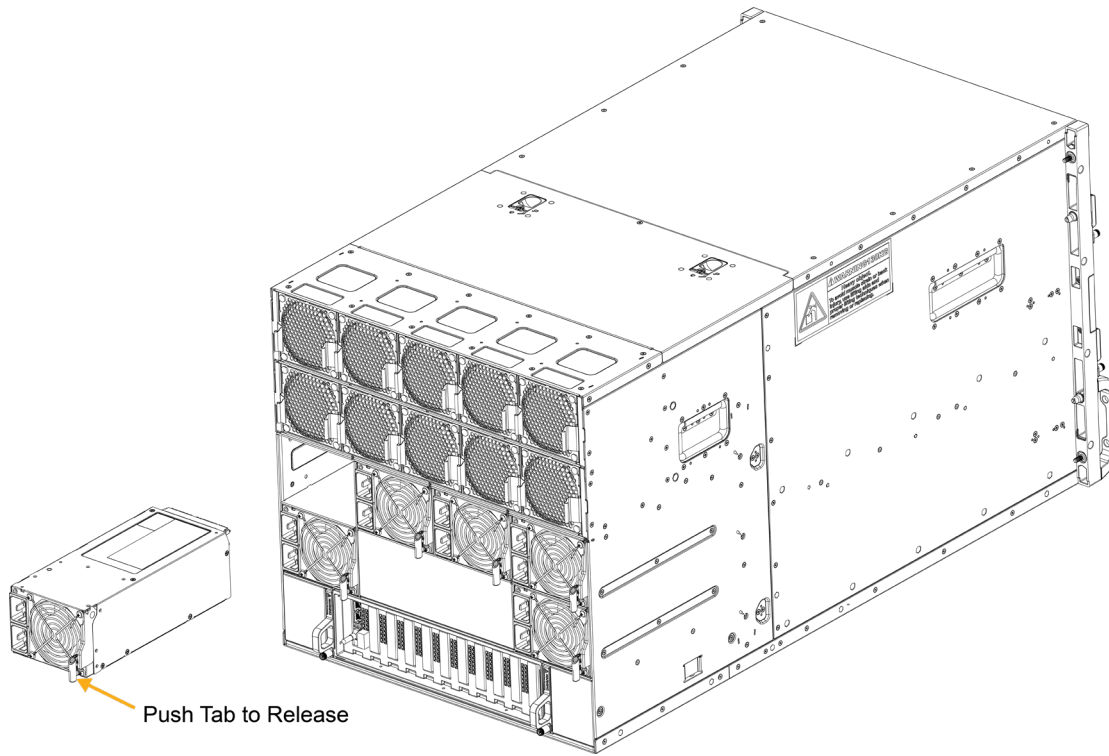

Figure 3-17. Installing a Power Supply Module

Caution: Do not attempt to lift the chassis by the empty power supply slot.

Chapter 4

Motherboard Connections

This section describes the connections on the motherboard and provides pinout definitions. Note that depending on how the system is configured, not all connections are required. The LEDs on the motherboard are also described here. A motherboard layout indicating component locations may be found in Chapter 1.

Please review the Safety Precautions in Chapter 3 before installing or removing components.

4.1 Power Connections

Power Supply Connectors

The power supply connector, located at P54V_JPWR1, provide main power to your system. Three power connectors (JSW_PWR1–JSW_PWR3) are used for front and backplane devices, five 8-pin power connectors (JPWR1–JPWR3, JPWR5–JPWR6) provide additional power for midplane devices. All these power connectors meet the ATX SSI EPS 12 V specification and must be connected to your power supply to provide adequate power to your system.

12V 8-pin Power Pin Definitions	
Pin#	Definition
1–4	Ground
5–8	+12V

Required Connection

4.2 Headers and Connectors

Fan Headers

There are six 4-pin fan headers (FAN1–FAN4, and FAN7–8). These fan headers are used for the cooling fans for your system. Additional power connector for the fan board is located at EJSW_P54V. Fan speed control for these fans is supported by Thermal Management via the BMC 2.0 interface.

TPM/Port 80 Header

The JTPM1 header is used to connect a TPM Module for Trust Platform Module/Port 80 support. The TPM module, which is optional and available from Supermicro, is a security device that supports encryption and authentication in hard drives. It allows the motherboard to deny access if the TPM associated with the hard drive is not installed in the system. Please go to the following link for more information on the TPM: <http://www.supermicro.com/manuals/other/TPM.pdf>.

Trusted Platform Module Header Pin Definitions			
Pin#	Definition	Pin#	Definition
1	+3.3V	2	SPI_CS#
3	RESET#	4	SPI_MISO
5	SPI_CLK	6	GND
7	SPI_MOSI	8	NC
9	+3.3V Stdby	10	SPI_IRQ#

6-pin BMC External I²C Header

A System Management Bus header for the BMC is located at JIPMB1. Connect the appropriate cable here to use the IPMB I²C connection on your system. Refer to the layout for the location of JIPMB1.

NC-SI Connector

The NC-SI (Network Controller Sideband Interface) connector is located at (JNCSIBF3). This connector is used to connect a Network Interface Card (NIC) to the motherboard to allow the onboard BMC (Baseboard Controller) to communicate with a network.

Note: For detailed instructions on how to configure Network Interface Card (NIC) settings, please refer to the Network Interface Card Configuration User's Guide posted on the web page under the link: <http://www.supermicro.com/support/manuals/>.

PCIe 3.0 M.2 Slots

Two PCIe 3.0 M.2 slots are located at JM2_1 and JM_2 on the motherboard. These M.2 slots support PCIe 3.0 M.2 NVMe SSDs in the 2280 and 22110 form factors. To accommodate the 2280 and 22110 form factors, four M.2 mounting holes (MH13–MH16) are provided on the motherboard. Use Mounting Hole MH13/MH15 for JM2_1 slot support, and MH14/MH16 for JM2_2 slot support. M.2 allows for a variety of card sizes, increased functionality, and spatial efficiency.

NVMe Connectors

Four MCIO NVMe connectors, located at JMCIO2A and EJNVME1–EJNVME4, provide ten PCIe 5.0 x16 connections on the motherboard. Use these MCIO connectors to support backplane PCIe storage devices.

4.3 Control Panel

Control Panel Header with I²C

The control panel header, located at JFP1, contains header pins for various buttons and LED indications with I²C support for front access. This front control panel header is designed specifically for use with Supermicro chassis. See the figure below for the pin-out descriptions of JFP1.

JFP1	
1	Power Button
2	Reset/UID Button
3	UID LED_N
4	Fail LED_N (OH/FF/PF)
5	LAN-2 Activity LED
6	LAN-1 Activity LED (Aggregate all LAN)
7	HDD Activity LED
8	Standby LED_N
9	Power/RoT LED_N
10	P3V3_STBY
11	Ground
12	I2C Data
13	I2C Clock
14	Ground
15	Power Fail LED_P
16	P5V_USB
17	P5V_USB
18	P5V_USB
19	Power Fail LED_N
20	Ground

Figure 4-1. JFP1 Pinouts

Power On and BMC/BIOS Status LED Button

The Power On and BMC/BIOS Status LED button is located on pin 1 of JFP1. Momentarily contacting pin 1 of JFP1 will power on/off the system or display the BMC/BIOS status. Refer to the table below for more information.

Power Button BMC/BIOS Status LED Indicator	
Status	Event
Green: solid on	System power on
BMC/BIOS blinking green at 4 Hz	BMC/BIOS checking
BIOS blinking gree at 4 Hz	BIOS recovery/update in progress
BMC blinking red x2 (2 blinks red) at 4 Hz, 1 pause at 2 Hz (on-on-off-off)	BMC recovery/update in progress
BMC/BIOS blinking green at 1 Hz	Flash not detected or golden image checking failure

UID LED

The unit identifier LED connection is located on pin 3 of JFP1.

Fail LED (Information LED for OH/FF/PF)

The Fail LED (Information LED for OH/Fan Fail/PWR Fail) connection is located on pin 4 of JFP1. The LED provides warnings of overheating, power failure, or fan failure. Refer to the table below for more information.

Fail LED (Information LED) (OH/Fan Fail/PWR Fail) LED States	
Status	Description
Solid red (on)	An overheat condition has occurred.
Blinking red (1 Hz)	Fan failure: check for an inoperative fan.
Blinking red (0.25 Hz)	Power failure: check for a non-operational power supply
Blinking red (10 Hz) (FP red LED)	CPLD recovery mode error(s)
Solid blue	UID has been activated locally. Use this function to locate a unit in a rack mount environment that might be in need of service.
Blinking blue (1 Hz)	Local UID has been activated locally on. Use this function to identify a unit that might be in need of service.
BIOS/BMC blinking blue (10 Hz)	BIOS/BMC: recovery and/or update in progress
Red Info LED blinking (10 Hz) and MB UID LED blue blinking (10 Hz)	CPLD: recovery and/or update in progress

LAN1/LAN2 (NIC1/NIC2)

The NIC (Network Interface Controller) LED connection for LAN Port 1 is located on pin 6 of JFP1, and the connection for LAN Port 2 is on pin 5.

LAN1/LAN2 LED LED States	
Color	State
NIC 2: Blinking green	LAN 2: Active
NIC 1: Blinking green	LAN 1: Active

HDD Activity LED

The storage drive activity LED connection is located on pin 7 of JFP1. When this LED is blinking green, it indicates drive activity.

HDD LED LED State	
Color	State
Blinking Green	HDD Active

Standby Power LED

The LED indicator for standby power is located on pin 8 of JFP1. If this LED is on, standby power is on.

RoT (Root of Trust) Power LED

The Power LED for RoT (Root of Trust) connection is located on pin 9 of JFP1. If this LED is on, power for the RoT chip is on.

Standby Power

A Standby Power (I²C) connection is located on pins 10–14 of JFP1 to provide power to the system when it is in standby mode.

3.3V Standby PWR Pin Definitions	
Pin#	Definition
10	P3V3 Standby
11	Ground
12	I ² C Data
13	I ² C Clock
14	Ground

Power Fail LED Indicators

Power Failure LED Indicators are located on pin 15 and pin 19 of JFP1.

FP Power LED Pin Definitions (JFP1)	
Pin#	Definition
15	PWR Failure LED-Positive
19	PWR Failure LED-Negative

FP USB Power

Pins 16-18 are used to provide power to front USB devices.

FP USB PWR Pin Definitions	
Pin#	Definition
16	
17	+5V USB PWR
18	

4.4 Input/Output Ports

VGA Connection

The front VGA header is located on JVGA1 on the motherboard. The VGA connection provides analog interface support between the computer and the video displays.

Universal Serial Bus (USB) 3.2 Header

A USB header that supports two USB 3.2 Gen1 ports is located at JUSB1 on the motherboard. These USB ports can be used for USB support via USB cables (not included). JP5V_USB provides power to the USB connections.

Rear I/O Panel (3.2 Gen1) Pin Definitions			
Pin#	Definition	Pin#	Definition
A1	VBUS	B1	Power
A2	D-	B2	USB_N
A3	D+	B3	USB_P
A4	GND	B4	GND
A5	Stda_SSRX-	B5	USB3_RN
A6	Stda_SSRX+	B6	USB3_RP
A7	GND	B7	GND
A8	Stda_SSTX-	B8	USB3_TN
A9	Stda_SSTX+	B9	USB3_TP

4.5 Jumpers

How Jumpers Work

To modify the operation of the motherboard, jumpers can be used to choose between optional settings. Jumpers create shorts between two pins to change the function of the connector. Pin #1 is identified with a square solder pad on the printed circuit board. See the diagram below for an example of jumping pins 1 and 2. Refer to the motherboard layout page for jumper locations.

Note 1: On two-pin jumpers, "Closed" means the jumper is on and "Open" means the jumper is off the pins.

Note 2: Unplug the power cord from all power supplies before adjusting jumper settings.

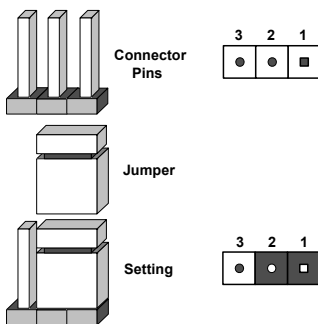

CMOS Clear

JBT1 is used to clear CMOS, which will also clear any passwords. Instead of pins, this jumper consists of contact pads to prevent accidentally clearing the contents of CMOS.

To Clear CMOS

1. First power down the system and unplug the power cord(s).
2. Remove the cover of the chassis to access the motherboard and remove the battery from the motherboard.
3. Short the CMOS pads, JBT1, with a metal object such as a small screwdriver for at least four seconds.
4. Remove the screwdriver (or shorting device).
5. Replace the cover, reconnect the power cord(s), and power on the system.

Note : Clearing CMOS will also clear all passwords.

BMC I²C/SDA to VRM and BMC I²C/SCI to VRM Select Jumper

Use JVRM1 to select between BMC I²C/SCL for VRM support. Use JVRM2 to select BMC I²C/SDA for VRM support. Connect a cable to JVRM1 and JVRM2 to enable BMC for VRM support. See the table below for jumper settings.

BMC I²C/SDA to VRM and BMC I²C/SCL to VRM Select Jumper Jumper Settings		
Pin Setting	Jumper Setting	Definition
Pins 1–2	Closed	(Default)
Pins 1–2	Open	Enable BMC for VRM support

4.6 LED Indicators

Onboard Power LED

The Onboard Power LED is located at LEDPWR on the motherboard. When this LED is on, the system power is on. Be sure to turn off the system power and unplug the power cords before removing or installing components.

Onboard Power LED Indicator	
LED Color	Definition
Off	System Power Off (power cable not connected)
Green	System Power On

BMC Heartbeat LED

A BMC Heartbeat LED is located at LEDBMC on the motherboard. When LEDBMC is blinking green, the BMC is functioning normally.

BMC Heartbeat LED Indicator	
LED Color	Definition
Green: Blinking	BMC Normal

Chapter 5

Software

After the hardware has been installed, you can install the Operating System (OS), configure RAID settings, and install the drivers.

5.1 Microsoft Windows OS Installation

If you will be using RAID, you must configure RAID settings before installing the Windows OS and the RAID driver. Refer to the RAID Configuration User Guides posted on our website at www.supernmicro.com/support/manuals.

Installing the OS

1. Create a method to access the Microsoft Windows installation ISO file. That can be a USB flash or media drive.
2. Retrieve the proper RST/RSTe driver. Go to the Supermicro web page for your motherboard and click on "Download the Latest Drivers and Utilities", select the proper driver, and copy it to a USB flash drive.
3. Boot from a bootable device with Windows OS installation. You can see a bootable device list by pressing **<F11>** during the system startup.

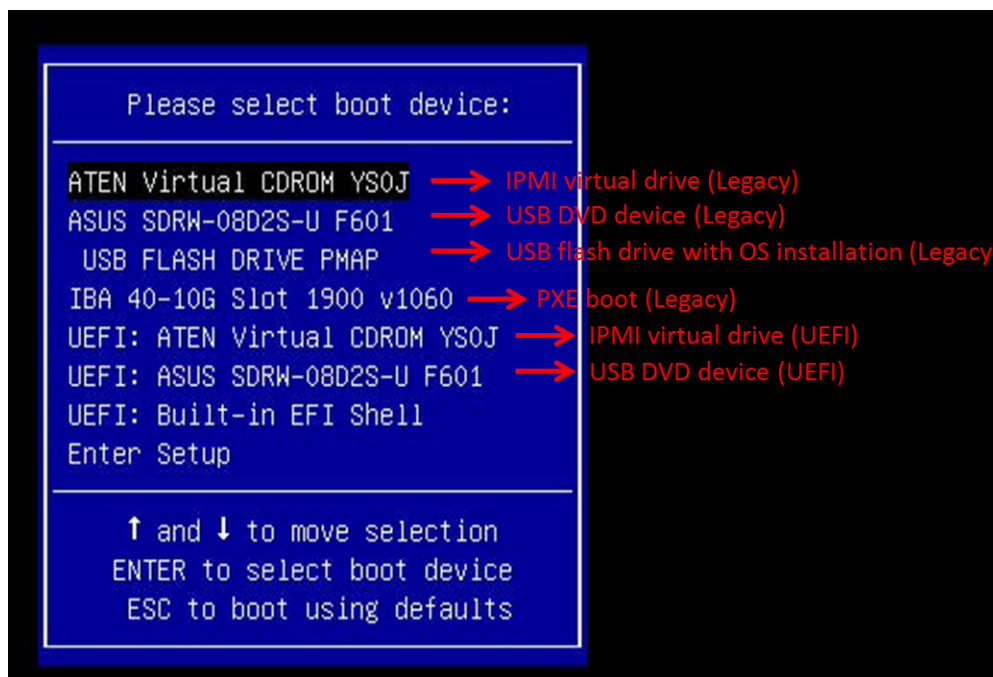

Figure 5-1. Select Boot Device

4. During Windows Setup, continue to the dialog where you select the drives on which to install Windows. If the disk you want to use is not listed, click on “Load driver” link at the bottom left corner.

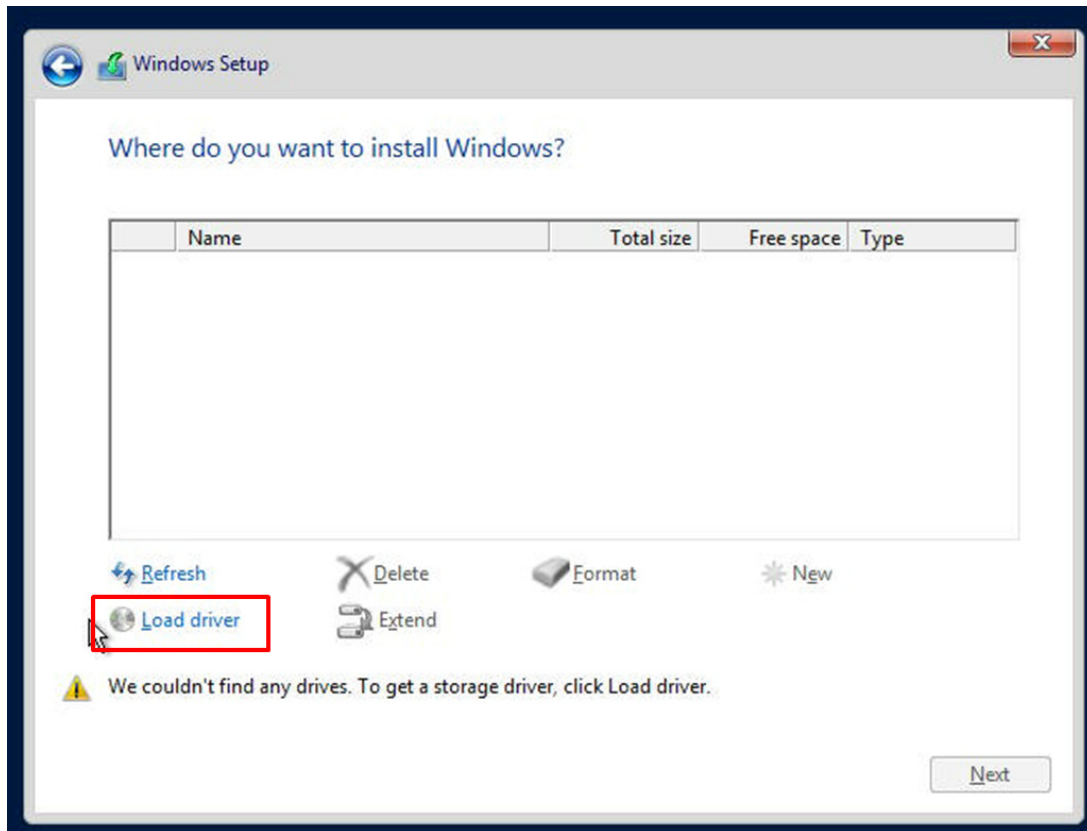

Figure 5-2. Load Driver Link

To load the driver, browse the USB flash drive for the proper driver files.

- For RAID, choose the SATA/sSATA RAID driver indicated then choose the storage drive on which you want to install it.
 - For non-RAID, choose the SATA/sSATA AHCI driver indicated then choose the storage drive on which you want to install it.
5. Once all devices are specified, continue with the installation.
 6. After the Windows OS installation has completed, the system will automatically reboot multiple times.

5.2 Driver Installation

The Supermicro website contains drivers and utilities for your system at <https://www.supermicro.com/wdl/>. Some of these must be installed, such as the chipset driver.

After accessing the website, go into the CDR_Images (in the parent directory of the above link) and locate the ISO file for your motherboard. Download this file to a USB flash or media drive. (You may also use a utility to extract the ISO file if preferred.)

Another option is to go to the Supermicro website at <http://www.supermicro.com/products/>. Find the product page for your motherboard, and "Download the Latest Drivers and Utilities".

Insert the flash drive or disk and the screenshot shown below should appear.

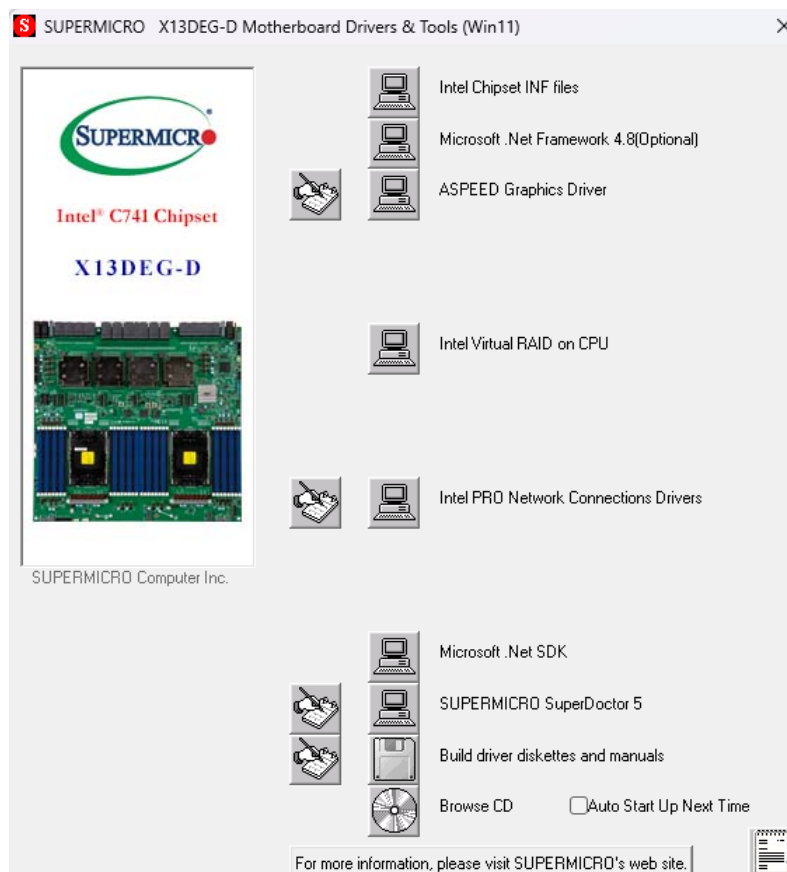

Figure 5-3. Driver & Tool Installation Screen

Note: Click the icons showing a hand writing on paper to view the readme files for each item. Click the computer icons to the right of these items to install each item (from top to the bottom) one at a time. **After installing each item, you must re-boot the system before moving on to the next item on the list.** The bottom icon with a CD on it allows you to view the entire contents.

5.3 BMC

The X13DEG-M motherboard provides remote access, monitoring and management through the baseboard management controller (BMC) and other management controllers distributed among different system modules. There are several BIOS settings that are related to BMC. For general documentation and information on BMC, visit our website at:

<https://www.supermicro.com/products/nfo/BMC.cfm>.

5.4 Logging into the BMC

Supermicro ships standard products with a unique password for the BMC ADMIN user. This password can be found on a label on the motherboard.

When logging in to the BMC for the first time, please use the unique password provided by Supermicro to log in. After logging in, you can change the administrator password to protect your security. When logging in as an administrator, you can also create a user account and set the password of your choice for subsequent logins.

For more information regarding BMC passwords, please visit our website at

<https://www.supermicro.com/bmcpassword>.

Chapter 6

Optional Components

This chapter describes optional system components.

6.1 PCBs

PCB Options	
Part Number	Description
AOM-BB-GP102	MGX Grace server bridge board for front BF3 backplane connections
BPN-GP101M	8-slot PCIe x4 Gen5 direct-attached backplane

6.2 Cables

Cable Options	
Part Number	Description
CBL-CDAT-1120-60	Front BF3 NCSI cable
CBL-IPEX-1315	Front BF3 to bridge board cable
CBL-PWEX-1133-65	Backplane power cable
CBL-PWEX-1174-60	Front BF3 power cable

6.3 Drive Kits

Drive Kit Options	
Part Number	Description
MCP-220-80505-0N	2T cage for CPU tray

Chapter 7

Troubleshooting and Support

7.1 Information Resources

Website

A great deal of information is available on the Supermicro website, supermicro.com.

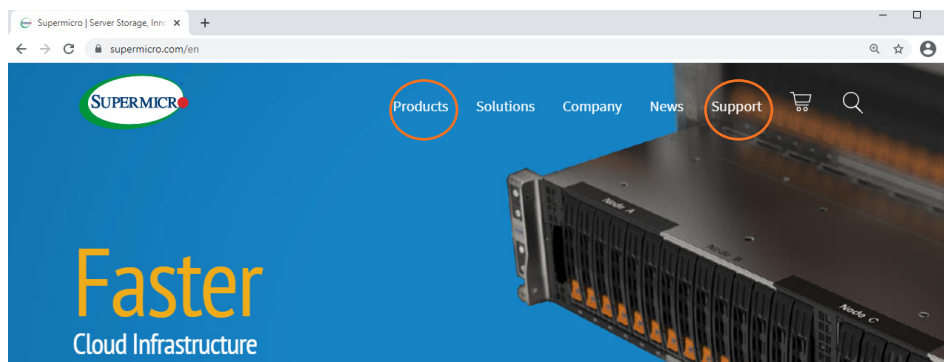

Figure 7-1. Supermicro Website

- Specifications for servers and other hardware are available by clicking the Products option.
- The Support option offers downloads (manuals, BIOS/BMC, drivers, etc.), FAQs, RMA, warranty, and other service extensions.

Direct Link for the SYS-A21GE-NBRT System

[SYS-A21GE-NBRT specifications page](#)

Direct Links for General Support and Information

[Frequently Asked Questions](#)

[Add-on card descriptions](#)

[TPM User Guide](#)

[BMC User Guide](#)

[SuperDoctor5 Large Deployment Guide](#)

For validated memory, use our [Product Resources page](#)

Direct Links (continued)

[Product Matrices](#) page for links to tables summarizing specs for systems, motherboards, power supplies, riser cards, add-on cards, etc.

[Security Center](#) for recent security notices

[Supermicro Phone and Addresses](#)

7.2 BMC Interface

The system supports a Baseboard Management Controller (BMC) interface. It provides remote access, monitoring and management. There are several BIOS settings related to the BMC.

For general documentation and information on the BMC, please visit our website at: https://www.supermicro.com/manuals/other/BMC_IPMI_X13_H13.pdf.

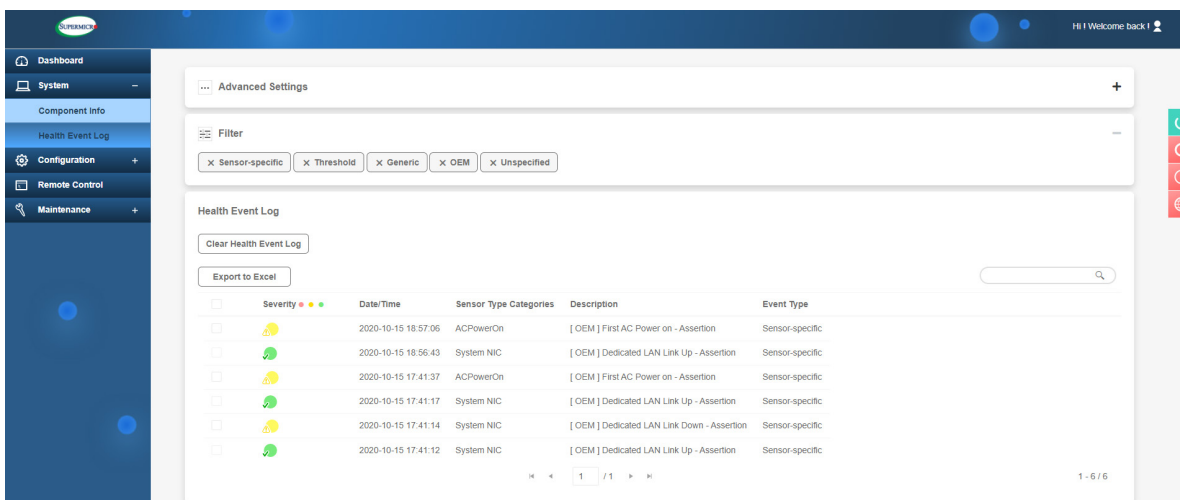

Figure 7-2. BMC Dashboard Sample

7.3 Troubleshooting Procedures

Use the following procedures to troubleshoot your system. If you have followed all of the procedures below and still need assistance, refer to the [Technical Support Procedures](#) or [Returning Merchandise for Service](#) sections in this chapter. Always disconnect the AC power cord before adding, changing, or installing any non hot-swap hardware components.

Before Power On

1. Make sure that there are no short circuits between the motherboard and chassis.
2. Disconnect all ribbon/wire cables from the motherboard, including those for the keyboard and mouse.
3. Remove all add-on cards.
4. Install the CPU (making sure it is fully seated) and connect the front panel connectors to the motherboard.

No Power

1. Check that the power LED on the motherboard is on.

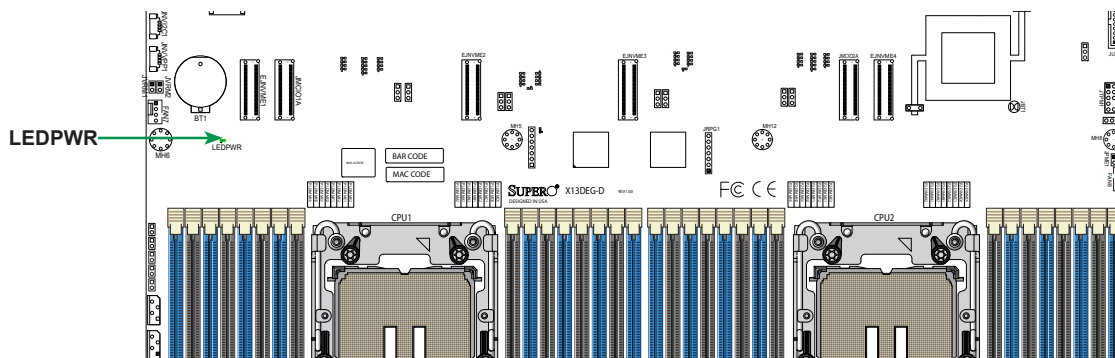

Figure 7-3. Location of the Power LED

2. Make sure that there are no short circuits between the motherboard and the chassis.
3. Make sure that the power supply connectors are properly connected.
4. Check that the 115 V/230 V switch, if available, on the power supply is properly set.
5. Turn the power switch on and off to test the system, if applicable.
6. The battery on your motherboard may be old. Check to verify that it still supplies approximately 3 VDC. If it does not, replace it with a new one.

No Video

1. If the power is on, but you do not have video, remove all add-on cards and cables.
2. Remove all memory modules and turn on the system (if the alarm is on, check the specs of memory modules, reset the memory, or try a different one).

System Boot Failure

If the system does not display Power-On-Self-Test (POST) or does not respond after the power is turned on, try the following:

1. Remove all components from the motherboard, especially the DIMM modules. Power on the system and check if the power-on LED (LEDPWR) and the BMC Heartbeat LED (LEDBMC) are on, and system fans are spinning.
2. Turn on the system with only one DIMM module installed. If the system boots, check for bad DIMM modules or slots by following the Memory Errors Troubleshooting procedure in this chapter.

Memory Errors

1. Make sure that the memory modules are compatible with the system and are properly installed. See [Chapter 3](#) for installation instructions. (For memory compatibility, refer to the "Tested Memory List" link on the motherboard's product page to see a list of supported memory.)
2. Check if different speeds of DIMMs have been installed. It is strongly recommended that you use the same RAM type and speed for all DIMM modules in the system.
3. Make sure that you are using the correct type of ECC DDR5 modules recommended by the manufacturer.
4. Check for bad DIMM modules or slots by swapping a single module among all memory slots and check the results.

Losing the System Setup Configuration

1. Make sure that you are using a high-quality power supply. A poor-quality power supply may cause the system to lose the CMOS setup information. Refer to [Chapter 1](#) for details on recommended power supplies.
2. The battery on your motherboard may be old. Check to verify that it still supplies approximately 3 VDC. If it does not, replace it with a new one.

If the System Becomes Unstable

A. If the system becomes unstable during or after OS installation, check the following:

1. CPU/BIOS support: Make sure that your CPU is supported and that you have the latest BIOS installed in your system.
2. Memory support: Make sure that the memory modules are supported by testing the modules using memtest86 or a similar utility.

Note: Click on the "Tested Memory List" link on the motherboard's product page to see a list of supported memory.

3. Storage drives support: Make sure that all drives work properly. Replace if necessary.
4. System cooling: Check the system cooling to make sure that all heatsink fans and CPU/system fans, etc., work properly. Check the hardware monitoring settings in the BMC to make sure that the CPU and system temperatures are within the normal range. Also check the front panel Overheat LED and make sure that it is not on.
5. Adequate power supply: Make sure that the power supply provides adequate power to the system. Make sure that all power connectors are connected. Refer to the Supermicro website for the minimum power requirements.
6. Proper software support: Make sure that the correct drivers are used.

B. If the system becomes unstable before or during OS installation, check the following:

1. Source of installation: Make sure that the devices used for installation are working properly, including boot devices such as USB flash or media drives
2. Cable connection: Check to make sure that all cables are connected and working properly.
3. Using the minimum configuration for troubleshooting: Remove all unnecessary components (starting with add-on cards first), and use the minimum configuration (but with the CPU and a memory module installed) to identify the trouble areas. Refer to the steps listed in Section A above for proper troubleshooting procedures.
4. Identify bad components by isolating them: If necessary, remove a component in question from the chassis, and test it in isolation to make sure that it works properly. Replace a bad component with a good one.
5. Check and change one component at a time of changing several items at the same time. This will help isolate and identify the problem.

6. To find out if a component is good, swap this component with a new one to see if the system will work properly. If so, then the old component is bad. You can also install the component in question in another system. If the new system works, the component is good and the old system has problems.

Issues with NVMe Storage Devices

The numbering of NVMe storage devices are not shown as sequential in the operating system.

This only happens after an M.2 NVMe device is installed. In the example of a twelve-bay system, NVMe4 (from CPU1) is occupied and NVMe9 (from CPU2) is occupied, causing the numbering of the NVMe storage devices in the operating system to be different from that of the physical presence of drives.

Before two M.2 device two installed:

NVMe2	NVMe5	NVMe8	NVMe11
NVMe1	NVMe4	NVMe7	NVMe10
NVMe0	NVMe3	NVMe6	NVMe9

After two M.2 devices are installed:

NVMe2	NVMe6	NVMe10	NVMe13
NVMe1	NVMe5	NVMe8	NVMe12
NVMe0	NVMe3	NVMe7	NVMe11

Note that NVMe4 and NVMe9 are gone. Once an M.2 NVMe device is installed, the operation system recognizes the storage devices based on the PCIe training sequences. (The numbering sequence begins with CPU1-connected devices and then CPU2-connected devices.)

An NVMe drive is successfully ejected via the BMC Web GUI, but it displays "Exception" in the log.

This is perfectly fine at this stage and will not affect your normal use of the drives and the BMC Web GUI.

7.4 BIOS POST Codes

The AMI BIOS supplies additional checkpoint codes, which are documented online at <http://www.supermicro.com/support/manuals/> ("AMI BIOS POST Codes User's Guide").

For information on AMI updates, please refer to <https://www.ami.com/products/>.

7.5 Technical Support Procedures

Before contacting Technical Support, please take the following steps. Also, please note that as a motherboard manufacturer, Supermicro also sells motherboards through its channels, so it is best to first check with your distributor or reseller for troubleshooting services. They should know of any possible problems with the specific system configuration that was sold to you.

1. Please go through the Troubleshooting Procedures and Frequently Asked Questions (FAQ) sections in this chapter or see the FAQs on our website (<https://www.supermicro.com/FAQ/index.php>) before contacting Technical Support.
2. BIOS upgrades can be downloaded from our website (https://www.supermicro.com/ResourceApps/BIOS_BMC_Intel.html).
3. If you still cannot resolve the problem, include the following information when contacting Supermicro for technical support:
 - Motherboard model and PCB revision number
 - BIOS release date/version (This can be seen on the initial display when your system first boots up.)
 - System configuration
4. An example of a Technical Support form is on our website at <https://www.supermicro.com/RmaForm/>.
5. Distributors: For immediate assistance, please have your account number ready when placing a call to our Technical Support department. We can be reached by email at support@supermicro.com.

7.6 Frequently Asked Questions

Question: What type of memory does my motherboard support?

Answer: This motherboard supports up to 8 TB 3DS RDIMM/RDIMM DDR5 (288-pin) ECC memory with speeds up to 4800 MT/s (1PDC) or 4400 MT/s (2DPC) in 32 DIMM slots. To enhance memory performance, do not mix memory modules of different speeds and sizes. Please follow all memory installation instructions given on [Section 3-4](#) in Chapter 3.

Question: How do I update my BIOS?

Answer: It is recommended that you do not upgrade your BIOS if you are not experiencing any problems with your system. Updated BIOS files are located on our website at https://www.supermicro.com/ResourceApps/BIOS_BMC_Intel.html. Please check our BIOS warning message and the information on how to update your BIOS on our website. Select your motherboard model and download the BIOS file to your computer. Also, check the current BIOS revision to make sure that it is newer than your BIOS before downloading.

Note 1: The SPI BIOS chip used on this motherboard cannot be removed. Send your motherboard back to our RMA Department at Supermicro for repair.

Note 2: For BIOS Update and Recovery instructions, please refer to the Firmware Update and Recovery Instructions for Supermicro's X13 Motherboards User's Guide posted at <https://www.supermicro.com/support/manuals/>.

Question: I use surprise hotplug to plug and unplug NVMe drives into the SYS-A21GE-NBRT system and the NVMe LED keeps flashing an amber light. I have Linux OS and the PLX FW is 4.15 - what's the problem?

Answer: The system only supports orderly hotplug under Linux with PLX GCA4.15 FW. Don't use surprise hotplug. If you use surprise hotplug and the NVMe LED begins flashing amber, reboot the system and the LED will turn to blue.

7.7 Battery Removal and Installation

Battery Removal

To remove the onboard battery, follow the steps below:

1. Power off your system and unplug your power cable.
2. Locate the onboard battery as shown below.
3. Using a tool such as a pen or a small screwdriver, push the battery lock outwards to unlock it. Once unlocked, the battery will pop out from the holder.
4. Remove the battery.

Proper Battery Disposal

Important: Please handle used batteries carefully. Do not damage the battery in any way; a damaged battery may release hazardous materials into the environment. Do not discard a used battery in the garbage or a public landfill. Please comply with the regulations set up by your local hazardous waste management agency to dispose of your used battery properly.

Battery Installation

To install an onboard battery, follow the steps below:

1. Power off your system and unplug your power cable.
2. Locate the onboard battery as shown below
3. Identify the battery's polarity. The positive (+) side should be facing up.
4. Insert the battery into the battery holder and push it down until you hear a click to ensure that the battery is securely locked.

Important: When replacing a battery, be sure to only replace it with the same type.

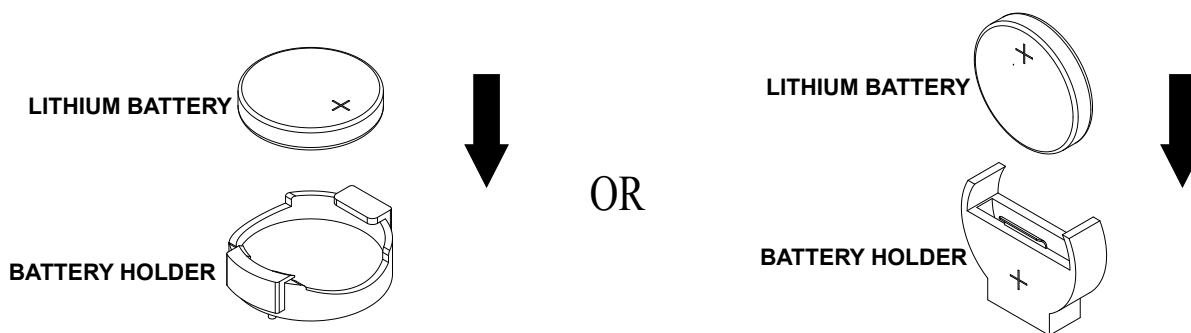

7.8 Where to Get Replacement Components

If you need replacement parts for your system, to ensure the highest level of professional service and technical support, purchase exclusively from our Supermicro Authorized Distributors/System Integrators/Resellers. A list can be found at: <http://www.supermicro.com>. Click the "Where to Buy" tab.

7.9 Reporting an Issue

Returning Merchandise for Service

A receipt or copy of your invoice marked with the date of purchase is required before any warranty service will be rendered. You can obtain service by calling your vendor for a Returned Merchandise Authorization (RMA) number. When returning to the manufacturer, the RMA number should be prominently displayed on the outside of the shipping carton, and mailed prepaid or hand-carried. Shipping and handling charges will be applied for all orders that must be mailed when service is complete.

For faster service, RMA authorizations may be requested online (<http://www.supermicro.com/support/rma/>).

This warranty only covers normal consumer use and does not cover damages incurred in shipping or from failure due to the alteration, misuse, abuse or improper maintenance of products.

During the warranty period, contact your distributor first for any product problems.

7.10 Feedback

Supermicro values your feedback as we strive to improve our customer experience in all facets of our business. To provide feedback on our manuals, please email us at techwriterteam@supermicro.com.

7.11 Contacting Supermicro

Headquarters

Address: Super Micro Computer, Inc.
980 Rock Ave.
San Jose, CA 95131 U.S.A.

Tel: +1 (408) 503-8000

Fax: +1 (408) 503-8008

Email: marketing@supermicro.com (General Information)
Sales-USA@supermicro.com (Sales Inquiries)
Government_Sales-USA@supermicro.com (Gov. Sales Inquiries)
support@supermicro.com (Technical Support)
RMA@supermicro.com (RMA Support)
Webmaster@supermicro.com (Webmaster)

Website: www.supermicro.com

Europe

Address: Super Micro Computer B.V.
Het Sterrenbeeld 28, 5215 ML
's-Hertogenbosch, The Netherlands

Tel: +31 (0) 73-6400390

Fax: +31 (0) 73-6416525

Email: Sales_Europe@supermicro.com (Sales Inquiries)
Support_Europe@supermicro.com (Technical Support)
RMA_Europe@supermicro.com (RMA Support)

Website: www.supermicro.nl

Asia-Pacific

Address: Super Micro Computer, Inc.
3F, No. 150, Jian 1st Rd.
Zhonghe Dist., New Taipei City 235
Taiwan (R.O.C)

Tel: +886-(2) 8226-3990

Fax: +886-(2) 8226-3992

Email: Sales-Asia@supermicro.com.tw (Sales Inquiries)
Support@supermicro.com.tw (Technical Support)
RMA@supermicro.com.tw (RMA Support)

Website: www.supermicro.com.tw

Appendix A

Standardized Warning Statements for AC Systems

About Standardized Warning Statements

The following statements are industry standard warnings, provided to warn the user of situations which have the potential for bodily injury. Should you have questions or experience difficulty, contact Supermicro's Technical Support department for assistance. Only certified technicians should attempt to install or configure components.

Read this appendix in its entirety before installing or configuring components in the Supermicro chassis.

These warnings may also be found on our website at http://www.supermicro.com/about/policies/safety_information.cfm.

Warning Definition



Warning! This warning symbol means danger. You are in a situation that could cause bodily injury. Before you work on any equipment, be aware of the hazards involved with electrical circuitry and be familiar with standard practices for preventing accidents.

警告!この警告サインは危険を意味します。人身事故につながる可能性がありますので、いずれの機器でも動作させる前に、電気回路に含まれる危険性に注意して、標準的な事故防止策に精通して下さい。

警告! 此警告符号代表危险。您正处于可能受到严重伤害的工作环境中。在您使用设备开始工作之前, 必须充分意识到触电的危险, 并熟练掌握防止事故发生的标准工作程序。请根据每项警告结尾的声明号码找到此设备的安全性警告说明的翻译文本。

警告! 此警告符号代表危险。您正處於可能身體可能會受損傷的工作環境中。在您使用任何設備之前, 請注意觸電的危險, 並且要熟悉預防事故發生的標準工作程序。請依照每一注意事項後的號碼找到相關的翻譯說明內容。

WICHTIGE SICHERHEITSHINWEISE.

Dieses Warnsymbol bedeutet Gefahr. Sie befinden sich in einer Situation, die zu Verletzungen führen kann. Machen Sie sich vor der Arbeit mit Geräten mit den Gefahren elektrischer Schaltungen und den üblichen Verfahren zur Vorbeugung vor Unfällen vertraut. Suchen Sie mit der am Ende jeder Warnung angegebenen Anweisungsnummer nach der jeweiligen Übersetzung in den übersetzten Sicherheitshinweisen, die zusammen mit diesem Gerät ausgeliefert wurden. BEWAHREN SIE DIESE HINWEISE GUT AUF.

INSTRUCCIONES IMPORTANTES DE SEGURIDAD.

Este símbolo de aviso indica peligro. Existe riesgo para su integridad física. Antes de manipular cualquier equipo, considere los riesgos de la corriente eléctrica y familiarícese con los procedimientos estándar de prevención de accidentes. Al final de cada advertencia encontrará el número que le ayudará a encontrar el texto traducido en el apartado de traducciones que acompaña a este dispositivo. GUARDE ESTAS INSTRUCCIONES.

IMPORTANTES INFORMATIONS DE SÉCURITÉ.

Ce symbole d'avertissement indique un danger. Vous vous trouvez dans une situation pouvant entraîner des blessures ou des dommages corporels. Avant de travailler sur un équipement, soyez conscient des dangers liés aux circuits électriques et familiarisez-vous avec les procédures couramment utilisées pour éviter les accidents. Pour prendre connaissance des traductions des avertissements figurant dans les consignes de sécurité traduites qui accompagnent cet appareil, référez-vous au numéro de l'instruction situé à la fin de chaque avertissement. CONSERVEZ CES INFORMATIONS.

תקנון הצהרות אזהרה

הצהרות הבאות הן אזהרות על פי תקני התעשייה, על מנת להזהיר את המשתמש מפני חבלה פיזית אפשרית. במידה ויש שאלות או היתקלות בבעיה כלשהי, יש ליצור קשר עם מחלקת תמיכה טכנית של סופרמיקרו. טכנאים מוסמכים בלבד רשאים להתקין או להגדיר את הרכיבים. יש לקרוא את הנספח במלואו לפני התקנת או הגדרת הרכיבים במארזי סופרמיקרו.

אֵלָּהּ בְּחַלָּה וְיָכִי אֵי תִּסְבֵּב בְּאִיבָה גִּסְדָּה זֶה הַזְהַר עָּחֵץ! תְּחַזְּרֵנוּ .
 קִבֵּל אֵי תְּעוֹל עַל אֵי הַעֲדָת, יָכִי עַל עֵלְנ בַּלְּוֹחַאֲזַל אֵל אֲבוֹתָ עֵי הַזְּוֹאֲרֵ
 הַכְּהִיבָאֵי

וְיָכִי עַל דְּרָה בַּלְּוֹאֲרָסַת הַבְּקָאֵי לֹו עָּ וְיָכִי חֲאֲדַת
 אֵסְתַּחֲזֵם רִקְנַב אֵי הַלְּוֹ שֻׁסַּב בְּחַלָּה זֶה כָּל תְּחַזְּרֵנוּ לְלַעֲשֵׁר תְּזַגְּוֹתָהּ

안전을 위한 주의사항.

이 경고 기호는 위험이 있음을 알려 줍니다. 작업자의 신체에 부상을 야기 할 수 있는 상태에 있게 됩니다. 모든 장비에 대한 작업을 수행하기 전에 전기회로와 관련된 위험요소들을 확인하시고 사전에 사고를 방지할 수 있도록 표준 작업절차를 준수해 주시기 바랍니다.

해당 번역문을 찾기 위해 각 경고의 마지막 부분에 제공된 경고문 번호를 참조하십시오

BELANGRIJKE VEILIGHEIDSINSTRUCTIES

Dit waarschuwings symbool betekent gevaar. U verkeert in een situatie die lichamelijk letsel kan veroorzaken. Voordat u aan enige apparatuur gaat werken, dient u zich bewust te zijn van de bij een elektrische installatie betrokken risico's en dient u op de hoogte te zijn van de standaard procedures om ongelukken te voorkomen. Gebruik de nummers aan het eind van elke waarschuwing om deze te herleiden naar de desbetreffende locatie.

BEWAAR DEZE INSTRUCTIES

Installation Instructions



Warning! Read the installation instructions before connecting the system to the power source.

警告!

システムを電源に接続する前に、設置手順書をお読み下さい。

警告!

将此系统连接电源前,请先阅读安装说明。

警告!

將系統與電源連接前，請先閱讀安裝說明。

Warnung!

Vor dem Anschließen des Systems an die Stromquelle die Installationsanweisungen lesen.

¡Advertencia!

Lea las instrucciones de instalación antes de conectar el sistema a la red de alimentación.

Attention!

Avant de brancher le système sur la source d'alimentation, consulter les directives d'installation.

אזהרה!

יש לקרוא את הוראות התקנה לפני חיבור המערכת למקור מתח.

تحذير!

اقر إرشادات التركيب قبل توصيل النظام إلى مصدر للطاقة

경고!

시스템을 전원에 연결하기 전에 설치 안내를 읽어주십시오.

Waarschuwing!

Raadpleeg de installatie-instructies voordat u het systeem op de voedingsbron aansluit.

Circuit Breaker



Warning! This product relies on the building's installation for short-circuit (overcurrent) protection. Ensure that the protective device is rated not greater than: 250 V, 20 A.

警告!

この製品は、短絡(過電流)保護装置がある建物での設置を前提としています。
保護装置の定格が250 V、20 Aを超えないことを確認下さい。

警告!

此产品的短路(过载电流)保护由建筑物的供电系统提供, 确保短路保护设备的额定电流不大于250 V、20 A。

警告!

此產品的短路(過載電流)保護由建築物的供電系統提供, 確保短路保護設備的額定電流不大於250 V、20 A。

Warnung!

Dieses Produkt ist darauf angewiesen, dass im Gebäude ein Kurzschluss bzw. Überstromschutz installiert ist. Stellen Sie sicher, dass der Nennwert der Schutzvorrichtung nicht mehr als: 250 V, 20 A beträgt.

¡Advertencia!

Este equipo utiliza el sistema de protección contra cortocircuitos (o sobrecorrientes) del edificio. Asegúrese de que el dispositivo de protección no sea superior a: 250 V, 20 A.

Attention!

Pour ce qui est de la protection contre les courts-circuits (surtension), ce produit dépend de l'installation électrique du local. Vérifiez que le courant nominal du dispositif de protection n'est pas supérieur à: 250 V, 20 A.

אזהרה!

מוצר זה מסתמך על הגנה המותקנת במבנים למניעת קצר חשמלי. יש לוודא כי
המכשיר המגן מפני הקצר החשמלי הוא לא יותר מ-250 V, 20 A.

تحذير!

هذا المنتج يعتمد على معدات الحماية من الدوائر القصيرة التي تم تثبيتها في

المبنى

تأكد من أن تقييم الجهاز الوقائي ليس أكثر من : 20 A, 250 V

경고!

이 제품은 전원의 단락(과전류)방지에 대해서 전적으로 건물의 관련 설비에 의존합니다.
보호장치의 정격이 반드시 250 V(볼트), 20 A(암페어)를 초과하지 않도록 해야 합니다.

Waarschuwing!

Dit product is afhankelijk van de kortsluitbeveiliging (overspanning) van uw elektrische installatie. Controleer of het beveiligde apparaat niet groter gedimensioneerd is dan 250 V, 20 A.

Power Disconnection Warning



Warning! The system must be disconnected from all sources of power and the power cord removed from the power supply module(s) before accessing the chassis interior to install or remove system components (except for hot-swap components).



警告!

システムコンポーネントの取り付けまたは取り外しのために、シャーシ内部にアクセスするには、システムの電源はすべてのソースから切断され、電源コードは電源モジュールから取り外す必要があります。

警告!

在你打开机箱并安装或移除内部器件前，必须将系统完全断电，并移除电源线。

警告！

在您打開機殼安裝或移除內部元件前，必須將系統完全斷電，並移除電源線。

Warnung

Das System muss von allen Quellen der Energie und vom Netzanschlusskabel getrennt sein, das von den Spg.Versorgungsteilmodulen entfernt wird, bevor es auf den Chassisinnenraum zurückgreift, um Systemsbestandteile anzubringen oder zu entfernen.

¡Advertencia!

El sistema debe ser disconnected de todas las fuentes de energía y del cable eléctrico quitado de los módulos de fuente de alimentación antes de tener acceso el interior del chasis para instalar o para quitar componentes de sistema.

Attention!

Le système doit être débranché de toutes les sources de puissance ainsi que de son cordon d'alimentation secteur avant d'accéder à l'intérieur du chasis pour installer ou enlever des composants de système.

אזהרה!

יש לנתק את המערכת מכל מקורות החשמל ויש להסיר את כבל החשמלי מהספק לפני גישה לחלק הפנימי של המארז לצורך התקנת או הסרת רכיבים.

تحذير!

يجب فصل انظاؤ من جميع مصادر انطاقت وإزانت سهك انكهرباء من وحدة امداد انطاقت قيم
انصل إلى امناطق انداخهيت نههيكم نتشيج أو إزانت مكناث الجهاز

경고!

시스템에 부품들을 장착하거나 제거하기 위해서는 쉐시 내부에 접근하기 전에 반드시 전원 공급장치로부터 연결되어있는 모든 전원과 전기코드를 분리해주어야 합니다.

Waarschuwing!

Voordat u toegang neemt tot het binnenwerk van de behuizing voor het installeren of verwijderen van systeem onderdelen, dient u alle spanningsbronnen en alle stroomkabels aangesloten op de voeding(en) van de behuizing te verwijderen

Equipment Installation



Warning! Only authorized personnel and qualified service persons should be allowed to install, replace, or service this equipment.

警告!

トレーニングを受け認定された人だけがこの装置の設置、交換、またはサービスを許可されています。

警告!

只有经过培训且具有资格的人员才能进行此设备的安装、更换和维修。

警告!

只有經過受訓且具資格人員才可安裝、更換與維修此設備。

Warnung!

Nur autorisiertes Personal und qualifizierte Servicetechniker dürfen dieses Gerät installieren, austauschen oder warten.

¡Advertencia!

Sólo el personal autorizado y el personal de servicio calificado deben poder instalar, reemplazar o dar servicio a este equipo.

Attention!

Seul le personnel autorisé et le personnel de maintenance qualifié doivent être autorisés à installer, remplacer ou entretenir cet équipement.

אזהרה!

יש לאפשר רק צוות מורשה ואנשי שירות מוסמכים להתקין, להחליף או לטפל בציוד זה.

تحذير!

ينبغي السماح فقط للموظفين المعتمدين وأفراد الخدمة المؤهلين بتركيب هذا الجهاز أو استبداله أو صيانته.

경고!

승인된 직원과 자격을 갖춘 서비스 담당자만이 이 장비를 설치, 교체 또는 서비스할 수 있습니다.

Waarschuwing!

Alleen geautoriseerd personeel en gekwalificeerd onderhoudspersoneel mag deze apparatuur installeren, vervangen of onderhouden.

Rack Stability Hazard



Warning! Stability hazard. The rack may tip over causing serious personal injury. Before extending the rack to the installation position, read the installation instructions.

警告!

安定性に危険があります。ラックが転倒して、重大な人身事故を引き起こす可能性があります。ラックを設置位置まで伸ばす前に、設置手順をお読みください。設置位置にあるスライドレールに取り付けられた機器に負荷をかけないでください。スライドレールに取り付けられた機器を設置位置に放置しないでください。

警告!

稳定性危険。机架可能会翻倒，造成严重的人身伤害。在将机架延伸到安装位置之前，请阅读安装说明。请勿在安装位置对滑轨安装的设备施加任何负载。请勿将滑轨安装的设备留在安装位置。

警告!

穩定性危險。機架可能會翻倒，造成嚴重的人身傷害。將機架延伸至安裝位置前，請先閱讀安裝說明。請勿在安裝位置的滑軌安裝設備上放置任何負載。請勿將滑軌安裝設備留在安裝位置。

Warnung!

Gefahr der Instabilität. Das Rack kann umkippen und schwere Verletzungen verursachen. Lesen Sie die Installationsanweisungen, bevor Sie das Rack in die Einbauposition ausfahren. Belasten Sie die auf den Gleitschienen montierten Geräte nicht in der Einbauposition. Lassen Sie die auf den Gleitschienen montierten Geräte nicht in der Einbauposition.

¡Advertencia!

Peligro de inestabilidad. El rack podría volcarse y causar lesiones personales graves. Antes de extender el rack a la posición de instalación, lea las instrucciones de instalación. No coloque ninguna carga sobre el equipo montado sobre rieles deslizantes en la posición de instalación. No deje el equipo montado sobre rieles deslizantes en la posición de instalación. Sólo el personal autorizado y el personal de servicio calificado deben poder instalar, reemplazar o dar servicio a este equipo.

Avertissement!

Danger d'instabilité. Le rack peut basculer et provoquer des blessures corporelles graves. Avant d'étendre le rack en position d'installation, lire les instructions d'installation. Ne pas charger l'équipement monté sur rail de glissière en position d'installation. Ne pas laisser l'équipement monté sur rail de glissière en position d'installation.

אזהרה!

סכנת חוסר יציבות

המתלה עלול להתהפך ולגרום לפציעה חמורה

לפני הארכת המתלה למצב ההתקנה, קרא את הוראות ההתקנה

אין להעמיס כל עומס על הציוד המותקן על מסילת ההחלקה במצב ההתקנה

אל תשאיר את הציוד המותקן על מסילת ההחלקה במצב ההתקנה

تحذير!

خطر عدم الاستقرار.

قد ينقلب الرف مسبباً إصابات جسدية خطيرة.

قبل تمديد الرف إلى موضع التركيب، اقرأ تعليمات التركيب.

لا تضع أي حمولة على الجهاز المثبت على سكة الانزلاق في موضع التركيب.

لا تترك الجهاز المثبت على سكة الانزلاق في موضع التركيب.

경고!

안정성 위험. 랙이 넘어져 심각한 개인 부상을 입을 수 있습니다. 랙을 설치 위치까지 확장하기 전에 설치 지침을 읽으십시오. 설치 위치에서 슬라이드 레일 장착 장비에 하중을 가하지 마십시오. 슬라이드 레일 장착 장비를 설치 위치에 두지 마십시오.

Waarschuwing

Gevaar voor instabiliteit. Het rek kan kantelen en ernstig persoonlijk letsel veroorzaken. Lees de installatie-instructies voordat u het rek uitschuift naar de installatiepositie. Plaats geen last op de op de glijrail gemonteerde apparatuur in de installatiepositie. Laat de op de glijrail gemonteerde apparatuur niet in de installatiepositie staan.

Restricted Area



Warning! This unit is intended for installation in restricted access areas. A restricted access area can be accessed only through the use of a special tool, lock and key, or other means of security. (This warning does not apply to workstations).

警告！

このユニットは、アクセス制限区域に設置されることを想定しています。アクセス制限区域は、特別なツール、鍵と錠前、その他のセキュリティの手段を用いてのみ出入りが可能です。

警告！

此部件应安装在限制进出的场所。限制进出的场所指只能通过使用特殊工具、锁和钥匙或其它安全手段进出的场所。

警告！

此裝置僅限安裝於進出管制區域。進出管制區域係指僅能以特殊工具、鎖頭及鑰匙或其他安全方式才能進入的區域。

Warnung!

Diese Einheit ist zur Installation in Bereichen mit beschränktem Zutritt vorgesehen. Der Zutritt zu derartigen Bereichen ist nur mit einem Spezialwerkzeug, Schloss und Schlüssel oder einer sonstigen Sicherheitsvorkehrung möglich.

¡Advertencia!

Esta unidad ha sido diseñada para instalación en áreas de acceso restringido. Sólo puede obtenerse acceso a una de estas áreas mediante la utilización de una herramienta especial, cerradura con llave u otro medio de seguridad.

Attention!

Cet appareil doit être installée dans des zones d'accès réservés. L'accès à une zone d'accès réservé n'est possible qu'en utilisant un outil spécial, un mécanisme de verrouillage et une clé, ou tout autre moyen de sécurité.

אזהרה!

יש להתקין את היחידה באזורים שיש בהם הגבלת גישה. הגישה ניתנת בעזרת 'כלי אבטחה בלבד' (מפתח, מנעול וכד.).

تحذير!

اتخصيص هذه انحدة نترك بُها ف مناطق محظورة تم .
مَكن انصل إن منطقت محظورة فقط من خلال استخداو أداة خاصت،
أو أ وس هُت أخري نلالأما قفم ومفتاح

경고!

이 장치는 접근이 제한된 구역에 설치하도록 되어있습니다. 특수도구, 잠금 장치 및 키, 또는 기타 보안 수단을 통해서만 접근 제한 구역에 들어갈 수 있습니다.

Waarschuwing!

Dit apparaat is bedoeld voor installatie in gebieden met een beperkte toegang. Toegang tot dergelijke gebieden kunnen alleen verkregen worden door gebruik te maken van speciaal gereedschap, slot en sleutel of andere veiligheidsmaatregelen.

Battery Handling



CAUTION: There is risk of explosion if the battery is replaced by an incorrect type. Replace the battery only with the same or equivalent type recommended by the manufacturer. Dispose of used batteries according to the manufacturer's instructions

警告!

バッテリーを間違ったタイプに交換すると爆発の危険があります。交換する電池はメーカーが推奨する型、または同等のものを使用下さい。使用済電池は製造元の指示に従って処分して下さい。

警告!

如果更换的电池类型不正确，则存在爆炸危险。请只使用同类电池或制造商推荐的功能相当的电池更换原有电池。请按制造商的说明处理废旧电池。

警告!

如果更換的電池類型不正確，則有爆炸危險。請使用製造商建議之相同或功能相當的電池更換原有電池。請按照製造商的說明指示處理廢棄舊電池。

WARNUNG!

Es besteht Explosionsgefahr, wenn die Batterie durch einen falschen Typ ersetzt wird. Ersetzen Sie die Batterie nur durch den gleichen oder vom Hersteller empfohlenen Batterietyp. Entsorgen Sie die benutzten Batterien nach den Anweisungen des Herstellers.

ATTENTION!

Il existe un risque d'explosion si la batterie est remplacée par un type incorrect. Ne la remplacer que par une pile de type semblable ou équivalent, recommandée par le fabricant. Jeter les piles usagées conformément aux instructions du fabricant.

ADVERTENCIA!

Existe riesgo de explosión si la batería se reemplaza por un tipo incorrecto. Reemplazar la batería exclusivamente con el mismo tipo o el equivalente recomendado por el fabricante. Desechar las baterías gastadas según las instrucciones del fabricante.

אזהרה!

קיימת סכנת פיצוץ אם הסוללה תוחלף בסוג שגוי. יש להחליף את הסוללה בסוג התואם מחברת יצרן מומלצת. סילוק הסוללות המשומשות יש לבצע לפי הוראות היצרן.

تحذير!

هناك خطر الانفجار إذا تم استبدال البطارية بنوع غير صحيح.

استبدال البطارية

فقط بنفس النوع أو ما يعادلها مما أوصت به الشركة المصنعة

جخلص من البطاريات المسحومة وفقا لتعليمات الشركة الصانعة

경고!

배터리를 잘못된 종류로 교체하면 폭발의 위험이 있습니다. 기존 배터리와 동일하거나 제조사에서 권장하는 동등한 종류의 배터리로만 교체해야 합니다. 제조사의 안내에 따라 사용된 배터리를 처리하여 주십시오.

WAARSCHUWING!

Er bestaat explosiegevaar als de batterij wordt vervangen door een verkeerd type. Vervang de batterij slechts met hetzelfde of een equivalent type die door de fabrikant aanbevolen wordt. Gebruikte batterijen dienen overeenkomstig fabrieksvoorschriften afgevoerd te worden.

Redundant Power Supplies



Warning! This unit might have more than one power supply connection. All connections must be removed to de-energize the unit.

警告!

このユニットは複数の電源装置が接続されている場合があります。

ユニットの電源を切るためには、すべての接続を取り外さなければなりません。

警告!

此部件连接的电源可能不止一个。必须将所有电源断开才能停止给该部件供电。

警告!

此装置连接的电源可能不只一个。必须切断所有电源才能停止对该装置的供电。

Warnung!

Dieses Gerät kann mehr als eine Stromzufuhr haben. Um sicherzustellen, dass der Einheit kein Strom zugeführt wird, müssen alle Verbindungen entfernt werden.

¡Advertencia!

Puede que esta unidad tenga más de una conexión para fuentes de alimentación. Para cortar por completo el suministro de energía, deben desconectarse todas las conexiones.

Attention!

Cette unité peut avoir plus d'une connexion d'alimentation. Pour supprimer toute tension et tout courant électrique de l'unité, toutes les connexions d'alimentation doivent être débranchées.

אזהרה!

ליחידה יש יותר מחיבור אחד של ספק. יש להסיר את כל החיבורים על מנת לרוקן את היחידה.

تحذير!

قد يكون لهذا الجهاز عدة اتصالات بوحدات امداد الطاقة . يجب إزالة كافة الاتصالات لعسل الوحدة عن الكهرباء

경고!

이 장치에는 한 개 이상의 전원 공급 단자가 연결되어 있을 수 있습니다. 이 장치에 전원을 차단하기 위해서는 모든 연결 단자를 제거해야만 합니다.

Waarschuwing!

Deze eenheid kan meer dan één stroomtoevoeraansluiting bevatten. Alle aansluitingen dienen verwijderd te worden om het apparaat stroomloos te maken.

Backplane Voltage



Warning! Hazardous voltage or energy is present on the backplane when the system is operating. Use caution when servicing.

警告!

システムの稼働中は危険な電圧または電力が、バックプレーン上にかかっています。修理する際には注意ください。

警告!

当系统正在进行时，背板上有很危险的电压或能量，进行维修时务必小心。

警告!

當系統正在進行時，背板上有很危險的電壓或能量，進行維修時務必小心。

Warnung!

Wenn das System in Betrieb ist, treten auf der Rückwandplatine gefährliche Spannungen oder Energien auf. Vorsicht bei der Wartung.

¡Advertencia!

Cuando el sistema está en funcionamiento, el voltaje del plano trasero es peligroso. Tenga cuidado cuando lo revise.

Attention!

Lorsque le système est en fonctionnement, des tensions électriques circulent sur le fond de panier. Prendre des précautions lors de la maintenance.

אזהרה!

קיימת סכנת מתח בפנל האחורי בזמן תפעול המערכת. יש להיזהר במהלך העבודה.

تحذير!

هناك خطر من التيار الكهربائي أو الطاقة المخزنة على اللوحة عندما يكون النظام يعمل. كن حذرا عند خدمة هذا الجهاز.

경고!

시스템이 동작 중일 때 후면판 (Backplane)에는 위험한 전압이나 에너지가 발생 합니다.
서비스 작업 시 주의하십시오.

Waarschuwing

Een gevaarlijke spanning of energie is aanwezig op de backplane wanneer het systeem in gebruik is. Voorzichtigheid is geboden tijdens het onderhoud.

Comply with Local and National Electrical Codes



Warning! Installation of the equipment must comply with local and national electrical codes.

警告!

機器の取り付けはその地方および国の電気規格に準拠する必要があります。

警告!

设备安装必须符合本地与本国电气法规。

警告!

設備安裝必須符合本地與本國電氣法規。

Warnung!

Die Installation der Geräte muss den Sicherheitsstandards entsprechen.

¡Advertencia!

La instalacion del equipo debe cumplir con las normas de electricidad locales y nacionales.

Attention!

L'équipement doit être installé conformément aux normes électriques nationales et locales.

אזהרה!

תיאום חוקי החשמל הארצי

התקנת הציוד חייבת להיות תואמת לחוקי החשמל המקומיים והארציים.

تحذير!

تركيب المعدات الكهربائية يجب أن يمتثل للقوايه المحلية والوطنية المتعلقة

بالكهرباء

경고!

현 지역 및 국가의 전기 규정에 따라 장비를 설치해야 합니다.

Waarschuwing!

Bij installatie van de apparatuur moet worden voldaan aan de lokale en nationale elektriciteitsvoorschriften.

Product Disposal



Warning! Ultimate disposal of this product should be handled according to all national laws and regulations.

警告!

この製品を廃棄処分する場合、国の関係する全ての法律・条例に従い処理する必要があります。

警告!

本产品的废弃处理应根据所有国家的法律和规章进行。

警告!

本產品的廢棄處理應根據所有國家的法律和規章進行。

Warnung!

Die Entsorgung dieses Produkts sollte gemäß allen Bestimmungen und Gesetzen des Landes erfolgen.

¡Advertencia!

Al deshacerse por completo de este producto debe seguir todas las leyes y reglamentos nacionales.

Attention!

La mise au rebut ou le recyclage de ce produit sont généralement soumis à des lois et/ou directives de respect de l'environnement. Renseignez-vous auprès de l'organisme compétent.

אזהרה!

סילוק המוצר

אזהרה!

סילוק סופי של מוצר זה חייב להיות בהתאם להנחיות וחוקי המדינה.

تحذير!

عند التخلص النهائي من هذا المنتج ينبغي التعامل معه وفقا لجميع القوانين والأنظمة الوطنية

경고!

이 제품은 해당 국가의 관련 법규 및 규정에 따라 폐기되어야 합니다.

Waarschuwing!

De uiteindelijke verwijdering van dit product dient te geschieden in overeenstemming met alle nationale wetten en reglementen.

Fan Warning



Warning! Hazardous moving parts. Keep away from moving fan blades. The fans might still be turning when you remove the fan assembly from the chassis. Keep fingers, screwdrivers, and other objects away from the openings in the fan assembly's housing.

警告!

回転部品に注意。運転中は回転部(羽根)に触れないでください。シャーシから冷却ファン装置を取り外した際、ファンがまだ回転している可能性があります。ファンの開口部に、指、ドライバー、およびその他のものを近づけないで下さい。

警告!

危险的可移动性零件。请务必与转动的风扇叶片保持距离。当您从机架移除风扇装置，风扇可能仍在转动。小心不要将手指、螺丝起子和其他物品太靠近风扇。

警告!

危險的可移動性零件。請務必與轉動的風扇葉片保持距離。當您從機架移除風扇裝置，風扇可能仍在轉動。小心不要將手指、螺絲起子和其他物品太靠近風扇。

Warnung!

Gefährlich Bewegende Teile. Von den bewegenden Lüfterblätter fern halten. Die Lüfter drehen sich u. U. noch, wenn die Lüfterbaugruppe aus dem Chassis genommen wird. Halten Sie Finger, Schraubendreher und andere Gegenstände von den Öffnungen des Lüftergehäuses entfernt.

¡Advertencia!

Riesgo de piezas móviles. Mantener alejado de las aspas del ventilador. Los ventiladores podran dar vuelta cuando usted quite ell montaje del ventilador del chasis. Mandtenga los dedos, los destornilladores y todos los objetos lejos de las aberturas del ventilador

Attention!

Pieces mobiles dangereuses. Se tenir a l'écart des lames du ventilateur Il est possible que les ventilateurs soient toujours en rotation lorsque vous retirerez le bloc ventilateur du châssis. Prenez garde à ce que doigts, tournevis et autres objets soient éloignés du logement du bloc ventilateur.

אזהרה!

חלקים נעים מסוכנים. התרחק מלהבי המאוורר בפעולה כאשר מסירים את חלקי המאוורר מהמארז, יתכן והמאווררים עדיין עובדים. יש להרחיק למרחק בטוח את האצבעות וכלי עבודה שונים מהפתחים בתוך המאוורר

تحذير!

تحذير! أجزاء متحركة خطيرة. ابتعد عن شفرات المروحة المتحركة. من الممكن أن المراوح لا تزال تدور عند إزالة كتلة المروحة من الهيكل يجب إبقاء الأصابع ومفكات البراغي وغيرها من الأشياء بعيدا عن الفتحات في كتلة المروحة.

경고!

움직이는 위험한 부품. 회전하는 송풍 날개에 접근하지 마세요. 새시로부터 팬 조립품을 제거할 때 팬은 여전히 회전하고 있을 수 있습니다. 팬 조립품 외관의 열려있는 부분들로부터 손가락 및 스크류드라이버, 다른 물체들이 가까이 하지 않도록 배치해 주십시오.

Waarschuwing!

Gevaarlijk bewegende onderdelen. Houd voldoende afstand tot de bewegende ventilatorbladen. Het is mogelijk dat de ventilator nog draait tijdens het verwijderen van het ventilatorsamenstel uit het chassis. Houd uw vingers, schroevendraaiers en eventuele andere voorwerpen uit de buurt van de openingen in de ventilatorbehuizing.

Power Cable and AC Adapter



Warning! When installing the product, use the provided or designated connection cables, power cables and AC adaptors. Using any other cables and adaptors could cause a malfunction or a fire. Electrical Appliance and Material Safety Law prohibits the use of UL or CSA -certified cables (that have UL/CSA shown on the cord) for any other electrical devices than products designated by Supermicro only.

警告!

製品を設置する場合、提供または指定および購入された接続ケーブル、電源コードとACアダプターを、該当する地域の条例や安全基準に適合するコードサイズやプラグと共に使用下さい。他のケーブルやアダプターを使用すると故障や火災の原因になることがあります。電気用品安全法は、ULまたはCSA認定のケーブル(UL/CSAマークがコードに表記)をSupermicroが指定する製品以外に使用することを禁止しています。

警告!

安装此产品时,请使用本身提供的或指定的或采购的连接线、电源线和电源适配器, 包含遵照当地法规和安全要求的合规的电源线尺寸和插头。使用其它线材或适配器可能会引起故障或火灾。除了Supermicro所指定的产品, 电气用品和材料安全法律规定禁止使用未经UL或CSA认证的线材。(线材上会显示UL/CSA符号)。

警告!

安裝此產品時,請使用本身提供的或指定的或採購的連接線、電源線和電源適配器, 包含遵照當地法規和安全要求的合規的電源線尺寸和插頭。使用其它線材或適配器可能會引起故障或火災。除了Supermicro所指定的產品, 電氣用品和材料安全法律規定禁止使用未經UL或CSA認證的線材。(線材上會顯示UL/CSA符號)。

Warnung!

Nutzen Sie beim Installieren des Produkts ausschließlich die von uns zur Verfügung gestellten Verbindungskabeln, Stromkabeln und/oder Adapter, die Ihre örtlichen Sicherheitsstandards einhalten. Der Gebrauch von anderen Kabeln und Adapter können Fehlfunktionen oder Feuer verursachen. Die Richtlinien untersagen das Nutzen von UL oder CAS zertifizierten Kabeln (mit UL/CSA gekennzeichnet), an Geräten oder Produkten die nicht mit Supermicro gekennzeichnet sind.

¡Advertencia!

Cuando instale el producto, utilice la conexión provista o designada o procure cables, Cables de alimentación y adaptadores de CA que cumplan con los códigos locales y los requisitos de seguridad, incluyendo el tamaño adecuado del cable y el enchufe. El uso de otros cables y adaptadores podría causar un mal funcionamiento o un incendio. La Ley de Seguridad de Aparatos Eléctricos y de Materiales prohíbe El uso de cables certificados por UL o CSA (que tienen el certificado UL / CSA en el código) para cualquier otros dispositivos eléctricos que los productos designados únicamente por Supermicro.

Attention!

Lors de l'installation du produit, utilisez les cables de connection fournis ou désigné ou achetez des cables, cables de puissance et adaptateurs respectant les normes locales et les conditions de securite y compris les tailles de cables et les prises electriques appropries. L'utilisation d'autres cables et adaptateurs peut provoquer un dysfonctionnement ou un incendie. Appareils électroménagers et la Loi sur la Sécurité Matériel interdit l'utilisation de câbles certifiés- UL ou CSA (qui ont UL ou CSA indiqué sur le code) pour tous les autres appareils électriques sauf les produits désignés par Supermicro seulement.

!הרהזא

רְחֹצֵל וּמֵאֲתוֹהּ וְאוֹ שֶׁכֶּרֶן רֶשֶׁא AC מִימֵאֲתָמוּ מִיִּקֶפֶס, מִיִּלְבֵּכֵב שֶׁמֵתִשְׁהֵל שִׁי, רְצוּמָה תֵא מִיִּנִיקָתָם רֶשֶׁאֵכ לֵכֵב שׁוּמִיִּשׁ . עֵקֶתָהּ לִבְכָה לֶשׁ הַנּוֹכֵחַ הַדִּימ לִלּוֹךְ, תּוּיִמּוֹקָמָה תּוּחִיטְבָה תּוּשִׁירְדֵל וּמֵאֲתוֹהּ רֶשֶׁאוּ, הַנִּקְתָּהּ לִמְשַׁחַה יִרְשִׁכְמֵב שׁוּמִיִּשָׁה יִקּוּחֵל מֵאֲתָהֵב . יִלְמִשַׁח רֶצֶק וְאוֹ הַלְקֵתֵל מִוִּרְגֵל לּוֹלַע, רְחֵא גּוֹסֵם מֵאֲתָם וְאוֹ לִבֵּכ לֶשׁ דּוֹק מֵהִילַע עִיפּוֹם רֶשֶׁאֵכ) UL-ב וְאוֹ UL-ב מִיִּכְמִסּוּמָה מִיִּלְבֵּכֵב שֶׁמֵתִשְׁהֵל רוֹסִיא מִיִּיק, תּוּחִיטְבָה יִקּוּחוּ דִּבְלֵב Supermicro י"ע מֵאֲתוֹהּ רֶשֶׁא רְצוּמֵב קֶר אֵלֵא, רְחֵא יִלְמִשַׁח רְצוּמֵב לֵכ רוֹבַע UL/CSA)

!رذحت

عند تركيب المنتج، قم باستخدام التوصيلات المتوفرة أو المحددة أو قم بشراء الكابلات الكهربائية ومحولات التيار المتردد مع الالتزام بقوانين ومتطلبات السلامة المحلّية بما في ذلك حجم الموصل والقابس السليم. استخدام أي كوابلات ومحولات أخرى قد يتسبب في عطل أو حريق. UL أو CSA يحظر قانون السلامة للأجهزة الكهربائية والمعدات استخدام الكابلات المعتمدة من قبل مع أي معدات أخرى غير المنتجات المعنية والمحددة من قبل (UL/CSA) والتي تحمل علامة.

경고!

경고! 제품을 설치할 때 현지 코드 및 적절한 굵기의 코드와 플러그를 포함한 안전 요구 사항을 준수하여 제공되거나 지정된 연결 혹은 구매 케이블, 전원 케이블 및 AC 어댑터를 사용하십시오.

다른 케이블이나 어댑터를 사용하면 오작동이나 화재가 발생할 수 있습니다. 전기 용품 안전법은 UL 또는 CSA 인증 케이블 (코드에 UL / CSA가 표시된 케이블)을 Supermicro가 지정한 제품 이외의 전기 장치에 사용하는 것을 금지합니다.

Waarschuwing!

Bij het aansluiten van het Product uitsluitend gebruik maken van de geleverde Kabels of een andere geschikte aan te schaffen Aansluitmethode, deze moet altijd voldoen aan de lokale voorschriften en veiligheidsnormen, inclusief de juiste kabeldikte en stekker. Het gebruik van niet geschikte Kabels en/of Adapters kan een storing of brand veroorzaken. Wetgeving voor Elektrische apparatuur en Materiaalveiligheid verbied het gebruik van UL of CSA -gecertificeerde Kabels (met UL/CSA in de code) voor elke andere toepassing dan de door Supermicro hiervoor beoogde Producten.

Appendix B

System Specifications

Processors

Supports dual 4th and 5th Gen Intel Xeon Scalable processors, in Socket E (LGA 4677), thermal design power (TDP) of up to 350W.

- 4th Gen: up to 60 cores and supports SP XCC, SP MCC, and Max Series (HBM) SKUs.
- 5th Gen: up to 64 cores and supports SP XCC and SP MCC SKUs.

Chipset

Intel PCH C741

BIOS

AMI 32 MB SPI Flash EEPROM

Memory

Supports up to 8 TB 3DS RDIMM/RDIMM DDR5 (288-pin) ECC memory with speeds up to 5600 MT/s (1PDC) or 4400 MT/s (2DPC) in 32 DIMM slots

Note: Memory speed and capacity support depends on the processors used in the system.

GPUs

Eight Nvidia SXM HGX B200 GPUs

Storage Drives

Ten PCIe 5.0 x4 NVMe U.2 drive bays

Two onboard NVMe M.2 slots

PCI Expansion Slots

Eight PCIe 5.0 x16 LP slots

Two PCIe 5.0 x16 FHHL slots

Input/Output

One VGA port

Two USB 3.0 ports

One TPM header

Motherboard

X13DEG-D: 17" x 15.95" (432 x 394 mm) (L x W), proprietary

Chassis

CSE-GP1001TS: 10U Rackmount, 17.6" x 17.2" x 33.2" (W x H x D), (449 x 339 x 843 cm)

System Cooling

Fifteen heavy-duty, 8-cm hot-swap fans

Four internal heavy-duty, 6-cm fans

Power Supply

PWS-5K26G-2R1, 5250 W, 3+3 redundant modules, 80Plus Titanium level

Input:

5250 W: 200-240 Vac, 50-60 Hz

Output:

+12 V, 125 A max.

+12 VSB, 4 A max.

Operating Environment

Operating Temperature: 10° to 35° C (50° to 95° F)

Non-operating Temperature: -40° to 60° C (-40° to 140° F)

Operating Relative Humidity: 8% to 90% (non-condensing)

Non-operating Relative Humidity: 5% to 95% (non-condensing)

Regulatory Compliance

FCC, ICES, CE, VCCI, RCM, UKCA, NRTL, CB

Applied Directives, Standards

EMC/EMI: 2014/30/EU (EMC Directive)

Electromagnetic Compatibility Regulations 2016

FCC Part 15

ICES-003

VCCI-CISPR 32

AS/NZS CISPR 32

BS/EN 55032

BS/EN 55035

CISPR 32

CISPR 35

BS/EN 61000-3-2

BS/EN 61000-3-3

BS/EN 61000-4-2

BS/EN 61000-4-3

BS/EN 61000-4-4

BS/EN 61000-4-5

BS/EN 61000-4-6

BS/EN 61000-4-8

BS/EN 61000-4-11

Environment:

Delegated Directive (EU) 2015/863

Directive 2011/65/EU (RoHS)

REACH Regulation EC 1907/2006

WEEE Directive 2012/19/EU

California Proposition 65

Product Safety: 2014/35/EU (LVD Directive)

UL/CSA 62368-1 (USA and Canada)

Electrical Equipment (Safety) Regulations 2016

IEC/BS/EN 62368-1

Perchlorate Warning

California Best Management Practices Regulations for Perchlorate Materials: This Perchlorate warning applies only to products containing CR (Manganese Dioxide) Lithium coin cells. "Perchlorate Material-special handling may apply. See www.dtsc.ca.gov/hazardouswaste/perchlorate"

この装置は、クラスA機器です。この装置を住宅環境で使用すると電波妨害を引き起こすことがあります。この場合には使用者が適切な対策を講ずるよう要求されることがあります。

VCCI — A

General Data Center Environmental Specifications

Particulate contamination specifications

Air filtration: Data centers must be kept clean to Class 8 of ISO 14644-1 (ISO 2015). The air entering the data center should be filtered with a MERV 11 filter or better. The air within the data center should be continuously filtered with a MERV 8 filter or better.

Conductive dust: Air should be free of conductive dust, zinc whiskers, or other conductive particles.

Corrosive dust: Air should be free of corrosive dust.

Gaseous* contamination specifications

Copper coupon corrosion rate: <300 Å/month per class G1 as defined by ANSI/ISA71.04-2013, referenced by ASHRAE TC 9.9

Silver coupon corrosion rate: <200 Å/month per class G1 as defined by ANSI/ISA71.04-2013, referenced by ASHRAE TC 9.9

*If testing with silver or copper coupons results in values less than 200 Å/month or 300 Å/month, respectively, then operating up to 70% relative humidity (RH) is acceptable. If the testing shows corrosion levels exceed these limits, then catalyst-type pollutants are probably present and RH should be driven to 50% or lower.